

– weishaupt –

manual

Installation and operating instructions

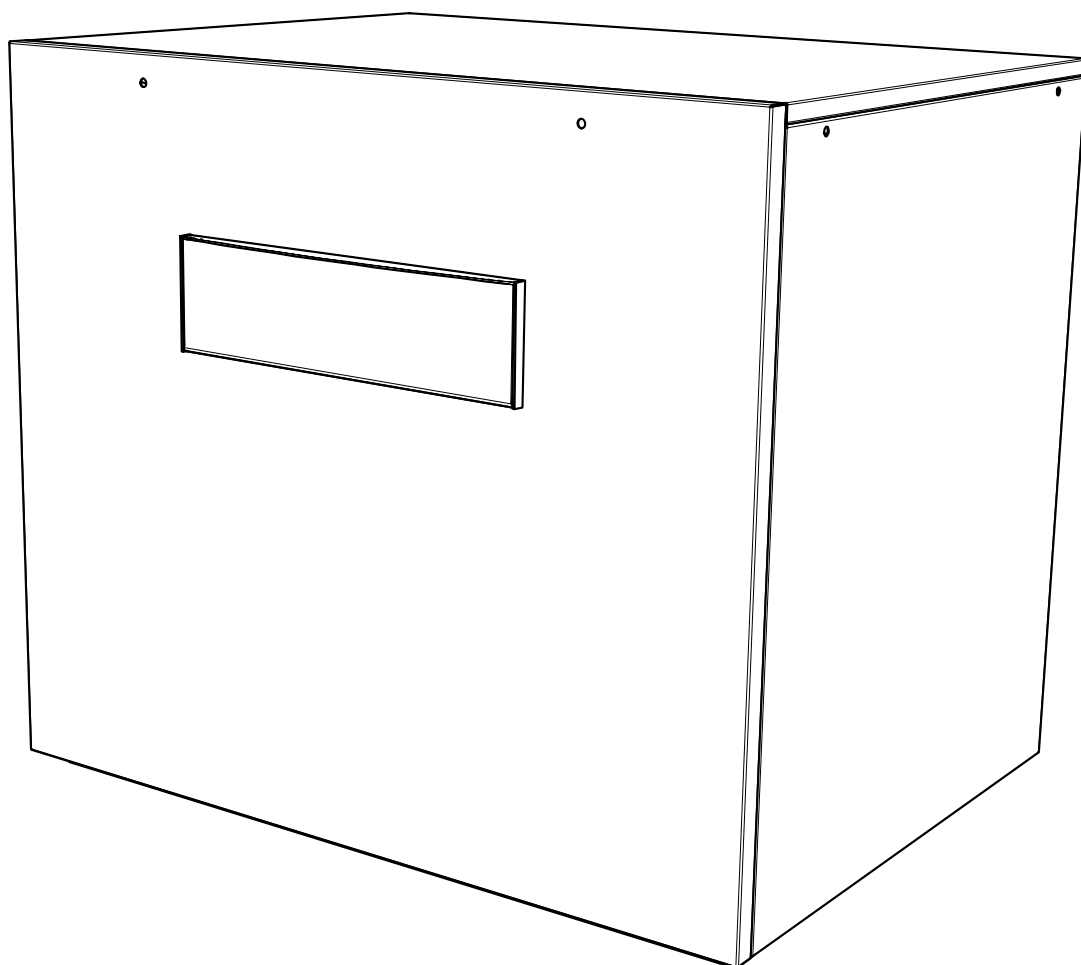

Table of contents

1	Safety notes	E-2
1.1	Symbols and markings	E-2
1.2	Intended use	E-2
1.3	Legal regulations and directives	E-2
1.4	Energy-efficient use of the heat pump	E-3
2	Intended use of the heat pump	E-4
2.1	Intended purpose	E-4
2.2	Operating principle	E-4
3	Basic device	E-5
4	Accessories	E-6
4.1	Connection flange	E-6
4.2	Remote control	E-6
4.3	Building management system	E-6
5	Transport	E-7
6	Installation	E-9
6.1	General Information	E-9
6.2	Acoustic Emissions	E-9
7	Installation	E-10
7.1	General	E-10
7.2	Connection on the heating side	E-10
7.3	Water Quality in Heating Systems	E-11
7.4	Heat source connection	E-12
7.5	Temperature sensor	E-13
7.6	Electrical connection	E-15
8	Commissioning	E-18
8.1	General Information	E-18
8.2	Preparation	E-18
8.3	Commissioning procedure	E-18
9	Cleaning / maintenance	E-19
9.1	Maintenance	E-19
9.2	Cleaning the heating system	E-19
9.3	Cleaning the heat source system	E-19
10	Faults / troubleshooting	E-20
11	Decommissioning / disposal	E-21
12	Device information	E-22
	Appendix	I

1 Safety notes

1.1 Symbols and markings

Particularly important information in these instructions is marked with CAUTION! and NOTE.

CAUTION

Immediate danger to life or danger of severe personal injury or significant damage to property.

Note

Risk of damage to property or minor personal injury or important information with no further risk of personal injury or damage to property.

1.2 Intended use

This device is only intended for use as specified by the manufacturer. Any other use beyond that intended by the manufacturer is prohibited. This requires the user to abide by the relevant project planning documents. Please refrain from tampering with or altering the device.

1.3 Legal regulations and directives

This heat pump is designed for use in a domestic environment according to Article 1, Paragraph 2 k) of EU directive 2006/42/EC (machinery directive) and is thus subject to the requirements of EU directive 2014/35/EU (low-voltage directive). It is thus also intended for use by non-professionals for heating shops, offices and other similar working environments, agricultural establishments and hotels, guesthouses and other residential buildings.

This heat pump conforms to all relevant DIN/VDE regulations and EU directives. Refer to the EC Declaration of Conformity in the appendix for details.

The heat pump must be connected to the power supply in compliance with all relevant VDE, EN and IEC standards. Any further connection requirements stipulated by local utility companies must also be observed.

The heat pump is to be connected to the heat source system and the heating system in accordance with all applicable regulations.

This unit can be used by children aged 8 and over and by persons with limited physical, sensory or mental aptitude or lack of experience and/or knowledge, providing they are supervised or have been instructed in the safe use of the unit and understand the associated potential dangers.

Children must not play with the device. Cleaning and user maintenance must not be carried out by children without supervision.

CAUTION

Work on the heat pump must only be performed by authorised and qualified after-sales service technicians!

CAUTION

When operating or maintaining a heat pump, the legal requirements of the country where the heat pump is operated apply. Depending on the refrigerant fill quantity, the heat pump must be inspected for leaks at regular intervals by a certified technician, and these inspections must be recorded.

More information can be found in the accompanying log book.

1.4 Energy-efficient use of the heat pump

By operating this heat pump you are helping to protect our environment. Both the heating system and the heat source must be properly designed and dimensioned to ensure efficient operation. It is particularly important to keep water flow temperatures as low as possible. All connected heat consumers should therefore be suitable for low flow temperatures. Raising the heating water temperature by 1 K corresponds to an increase in electricity consumption of approx. 2.5 %. Low-temperature heating systems with flow temperatures between 30 °C and 50 °C are particularly well-suited for energy-efficient operation.

2 Intended use of the heat pump

2.1 Intended purpose

The brine-to-water heat pump is to be used exclusively for the heating of heating water. It can be used in new or existing heating systems. A mixture of water and frost protection (brine) is used as a heat transfer medium in the heat source system. Borehole heat exchangers, ground heat collectors or similar systems can be used as the heat source system.

The circulating pump(s) must be controlled using the heat pump manager.

If function-relevant or safety-relevant pump functions, such as integration of the heat pump into the building management system, are not supported, then this can result in loss of warranty and cause a write-off of the heat pump.

The circulating pump(s) and the heat pump controller must always be ready for operation.

The specifications in the technical documents must be followed, particularly limit values for the minimum and – if available – maximum warm/cold water volume flow.

2.2 Operating principle

The heat generated by the sun, wind and rain is stored in the ground. This heat stored in the ground is collected at a low temperature by the brine circulating in the borehole heat exchanger or a similar system. A circulating pump then conveys the "heated" brine to the evaporator of the heat pump. There the heat is given off to the refrigerant in the refrigeration circuit. This cools the brine so that it can once again absorb thermal energy in the brine circuit.

The refrigerant is drawn in by the electrically driven compressor, compressed and "pumped" to a higher temperature level. The electrical power needed to run the compressor is not lost in this process. Most of it is absorbed by the refrigerant.

The refrigerant subsequently passes through the liquifier where it transfers its thermal energy to the heating water. Depending on the set operating point, the heating water can thus be heated up to a max. of 62 °C.

3 Basic device

The basic device consists of a heat pump for indoor installation wired ready for use with metal casing, switch box and integrated heat pump manager. The refrigeration circuit is "hermetically sealed" and contains the fluorinated refrigerant R410A included in the Kyoto protocol. Information on the GWP value and CO₂ equivalent of the refrigerant can be found in the chapter Device information. The refrigerant is CFC-free, non-ozone depleting and non-combustible.

All components required for the operation of the heat pump are located in the switch box. An outside temperature sensor including fixing accessories and a dirt trap are supplied with the heat pump. The supply for the supply voltage and the control voltage must be installed by the customer.

The circulating pumps (brine and heating water side) included in the scope of supply must be installed in accordance with the hydraulic diagrams or the development documents. The electrical connection of the circulating pumps must be established in accordance with Cap. 7.6.3 on page 16.

The customer must provide both the heat source system and the brine circuit manifold.

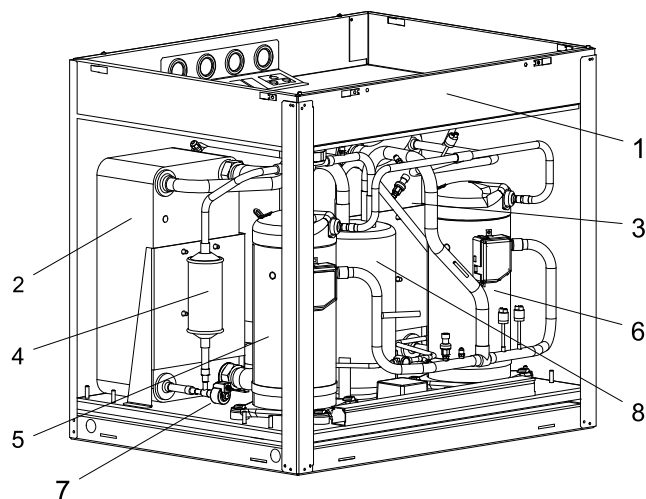

1. Switch box
2. Evaporator
3. Liquefier
4. Filter dryer
5. Compressor 1
6. Compressor 2
7. Expansion valve
8. Economiser

4 Accessories

4.1 Connection flange

The device can optionally be switched to flange connection using the flat-sealing connection flange.

4.2 Remote control

A remote display adds convenience and is available as a special accessory. Operation and menu navigation are identical to those of the heat pump manager. Connection takes place via an interface (special accessories) with RJ 12 Western plug.

Note

In the case of heating controllers with a removable control panel, this can also be used directly as a remote display.

4.3 Building management system

The heat pump manager can be connected to a building management system network via supplementation of the relevant interface plug-in card. The supplementary installation instructions of the interface card must be consulted regarding the exact connection and parameterisation of the interface.

The following network connections can be made on the heat pump manager:

- Modbus
- EIB, KNX
- Ethernet

CAUTION

If the heat pump or circulating pumps are controlled externally, a flow rate switch is required to prevent the compressor from being switched on when there is no volume flow.

5 Transport

A lift truck is suited for transporting the unit on a level surface. Carrying straps may be used if the heat pump needs to be transported on an uneven surface or carried up or down stairs. These straps can be passed directly underneath the pallet.

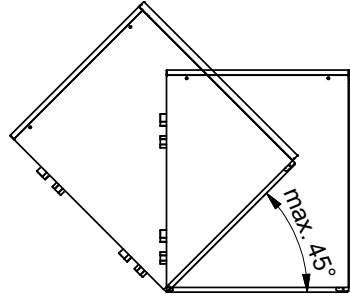

CAUTION

The heat pump must not be tilted more than 45° (in any direction).

Use the holes provided in the sides of the frame to lift the unit without the pallet. The side panel assemblies must be removed for this purpose. Any commercially available length of pipe can be used as a carrying aid.

After transportation, the transport fastening in the device is to be removed from both sides of the base.

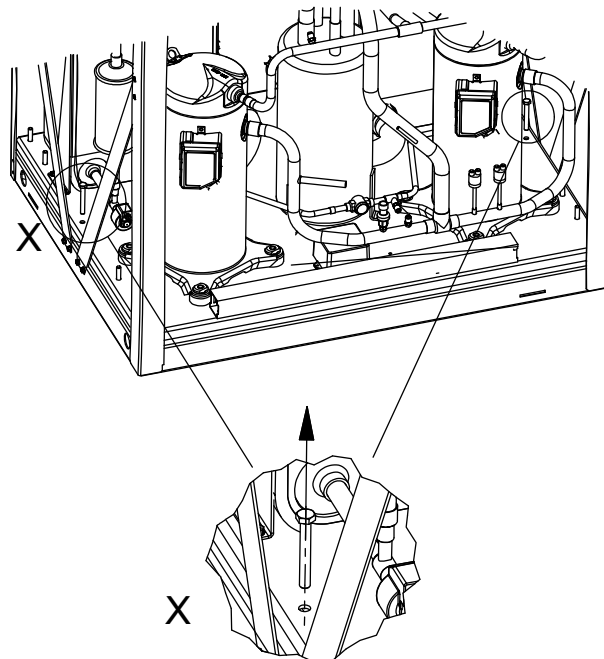

⚠ CAUTION

Before commissioning, the transport fastening must be removed.

All panelling can be removed to allow accessing the inside of the device.

Loosen the screws for this purpose. The panels can be removed toward the top when slightly tilted.

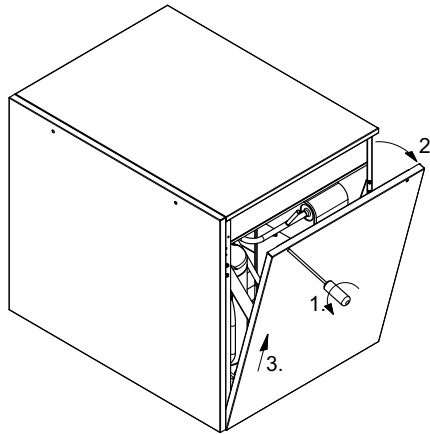

6 Installation

6.1 General Information

The heat pump has been designed for areas that are accessible to the general public, as well as for areas that are not accessible to the general public.

The brine-to-water heat pump must be installed in a frost-free, dry room on an even, smooth and horizontal surface. The entire base of the frame should lie directly on the floor to ensure an adequate soundproof seal. If this is not the case, additional sound insulation measures may be necessary.

The heat pump must be installed so that maintenance work can be carried out without hindrance. This can be ensured by maintaining a clearance of approx. 1 m in front of the heat pump.

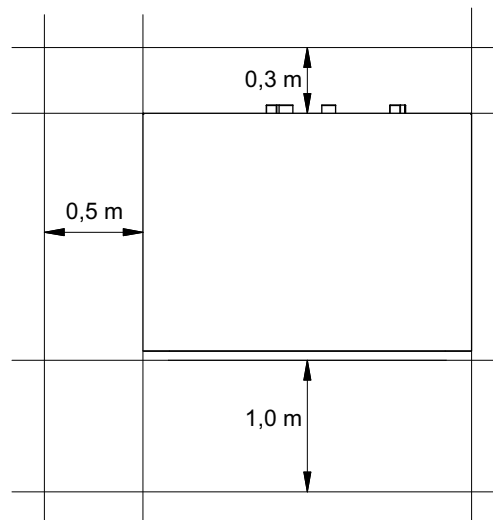

Neither frost nor temperatures higher than 35° must occur in the installation location at any time of the year.

⚠ Note

The heat pump is not intended for use over 2000 metres above sea level.

6.2 Acoustic Emissions

The heat pump operates silently due to efficient sound insulation. Internal insulation measures should be carried out to prevent vibrations from being transmitted to the foundation or to the heating system.

7 Installation

7.1 General

The following connections need to be established on the heat pump. The hydraulic integration diagram must be adhered to:

- Flow and return of the brine (heat source system)
- Flow and return of the heating system
- Temperature sensor
- Voltage supply

7.2 Connection on the heating side

CAUTION

Flush the heating system prior to connecting the heat pump.

Before connecting the heating water system to the heat pump, the heating system must be flushed to remove any impurities, residue from sealants, etc. Any accumulation of deposits in the liquifier could cause the heat pump to completely break down.

Once the heat pump has been connected to the heating system, it must be filled, de-aerated and pressure-tested.

CAUTION

The maximum test pressure in the heating circuit and the brine circuit is 6.0 bar. This value must not be exceeded.

Note

Pump units with check valves maintain the specified flow directions. If there is incorrect distribution or breaking off of the volume flow, these units (and the check valves in particular) must be checked! The use of check valves are mandatory in the event of several heating circuits or parallel connections for heat pumps in order to avoid incorrect distribution.

7.3 Water Quality in Heating Systems

⚠ Note

Damage due to unsuitable filling and additional water
Unsuitable filling and additional water can lead to deposits and corrosion. This can reduce the performance of the heat pump or cause damage to the system.

⚠ Note

The system installer is responsible for the water quality.

Do not use antifreeze (e.g. water / glycol mixture) in the heating water.

Flush the heating system before filling.

The filling water must meet drinking water standards and must comply with VDI 2035. The following limit values must also be observed:

Evaluation characteristic	Concentration range (mg/l or ppm)
Electrical conductivity (saline operation)	100 - 500 $\mu\text{S}/\text{cm}^1$
Electrical conductivity (low-salt operation)	< 100 $\mu\text{S}/\text{cm}^1$
pH value	8,2 - 9,5 ^{1 2 3}
Total hardness	3.5 - 8.4 °dH
Chloride ions (Cl^-)	< 20
Iron (Fe)	< 0.2 ¹
Hydrogen carbonate/sulphate ($\text{HCO}_3^-/\text{SO}_4^{2-}$)	> 1.0
Filterable materials	< 30

1. Values stipulated in VDI2035 are applicable
2. When using demineralised water, ensure that the pH value is above the minimum permissible value of 8.2. Failure to comply with this value can result in the heat pump being destroyed.
3. Check operation after 12 weeks at the latest.

Before filling the system, obtain information about the drinking water quality from the local water supply company. In many regions the local water supply company's website provide an insight into water hardness, pH value and a range of other constituent substances.

⚠ Note

Check the water quality 10 to 12 weeks after filling / commissioning.

⚠ Note

Document the filling water conditioning, water quality and any actions taken in the system handbook.

⚠ Note

It is mandatory to use hydraulically closed systems. It is not permissible to use any open hydraulic systems!

Minimum heating water flow rate

The minimum heating water flow rate through the heat pump must be assured in all operating states of the heating system. This can be accomplished, for example, by installing a dual differential pressureless manifold.

The frost protection function of the heat pump manager is active whenever the heat pump manager and the heat circulating pumps are ready for operation. The system must be drained if the heat pump is taken out of service or in the event of a power failure. If heat pump systems are implemented in buildings where a power failure cannot be detected (holiday homes etc.), the heating circuit should be operated with suitable frost protection.

7.4 Heat source connection

The following procedure must be observed when making the connection:

Connect the brine pipe to the heat source flow and return of the heat pump.

The hydraulic integration diagram must be adhered to.

 CAUTION

The supplied dirt trap must be inserted in the heat source inlet of the heat pump to protect the evaporator against the ingress of impurities.

The brine must be produced prior to charging the system. The brine concentration must be at least 25 %. This guarantees frost protection up to approx. -14 °C.

Only monoethylene glycol or propylene glycol-based antifreeze may be used.

The heat source system must be de-aerated and checked for leaks.

 CAUTION

The brine must contain at least a 25 % concentration of a monoethylene glycol or propylene glycol-based antifreeze, which must be mixed before filling.

 Note

If necessary, the operating range can be extended to a brine inlet temperature of -10 °C. In this case, the minimum brine concentration must be adjusted to 30 %. (Freezing temperature -17 °C).

 CAUTION

The maximum test pressure in the heating circuit and the brine circuit is 6.0 bar. This value must not be exceeded.

 CAUTION

A suitable de-aerator (micro bubble air separator) must be installed in the heat source circuit by the customer.

7.5 Temperature sensor

The following temperature sensors are already installed or must be installed additionally:

- Outside temperature sensor (R1) supplied (NTC-2)
- Return temperature secondary circuit (R2) installed (NTC-10)
- Return temperature primary circuit (R24) installed (NTC-10)
- Flow temperature secondary circuit (R9) installed (NTC-10)
- Flow temperature primary circuit (R6) installed (NTC-10)

7.5.1 Sensor characteristic curves

Temperature in °C	-20	-15	-10	-5	0	5	10
NTC-2 in kΩ	14.6	11.4	8.9	7.1	5.6	4.5	3.7
NTC-10 in kΩ	67.7	53.4	42.3	33.9	27.3	22.1	18.0

	15	20	25	30	35	40	45	50	55	60
	2.9	2.4	2.0	1.7	1.4	1.1	1.0	0.8	0.7	0.6
	14.9	12.1	10.0	8.4	7.0	5.9	5.0	4.2	3.6	3.1

The temperature sensors to be connected to the heat pump manager must correspond to the sensor characteristic curve illustrated in Fig. 7.1 on page 13. The only exception is the outside temperature sensor included in the scope of supply of the heat pump (see Fig. 7.2 on page 13)

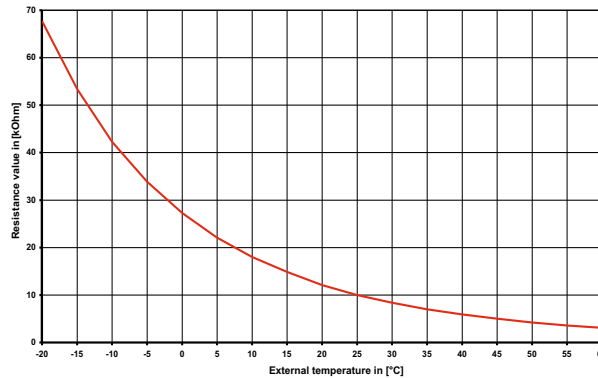

Fig. 7.1: Sensor characteristic curve NTC-10

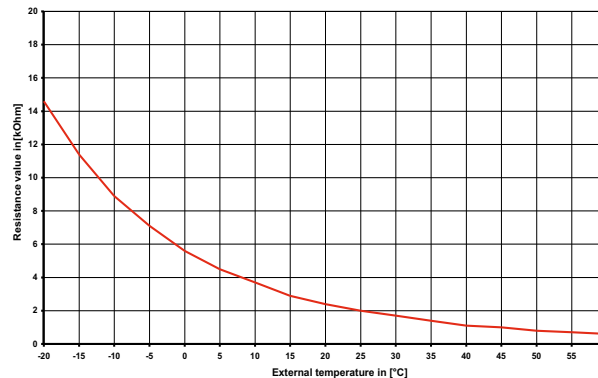

Fig. 7.2: Sensor characteristic curve NTC-2 according to DIN 44574 Outside temperature sensor

7.5.2 Mounting the outside temperature sensor

The temperature sensor must be mounted in such a way that all weather conditions are taken into consideration and the measured value is not falsified.

- Mount on the external wall on the north or north-west side where possible
- Do not install in a “sheltered position” (e.g. in a wall niche or under a balcony)
- Not in the vicinity of windows, doors, exhaust air vents, external lighting or heat pumps
- Not to be exposed to direct sunlight at any time of year

Dimensioning parameter sensor lead

Conductor material	Cu
Cable-length	50 m
Ambient temperature	35 °C
Laying system	B2 (DIN VDE 0298-4 / IEC 60364-5-52)
External diameter	4-8 mm

7.5.3 Installing the strap-on sensor

It is only necessary to mount the strap-on sensors if they are included in the scope of supply of the heat pump but have not yet been installed.

The strap-on sensors can be fitted as pipe-mounted sensors or installed in the immersion sleeve of the compact manifold.

Mounting as a pipe-mounted sensor

- Remove paint, rust and scale from heating pipe.
- Coat the cleaned surface with heat transfer compound (apply sparingly).
- Attach the sensor with a hose clip (tighten firmly, as loose sensors can cause malfunctions) and thermally insulate.

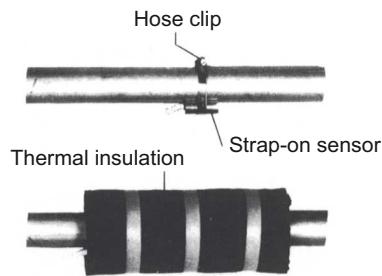

7.5.4 Hydraulic distribution system

The compact manifold and the hydraulic switch function as an interface between the heat pump, the heating distribution system, the buffer tank and, in some cases, also the domestic hot water cylinder. A compact system is used to simplify the installation process, so that a lot of different components do not have to be installed individually. Further information can be found in the relevant installation instructions.

7.6 Electrical connection

7.6.1 General

All electrical installation work must be carried out by a trained electrician or a specialist for the specified tasks in accordance with the

- installation and operating instructions,
- country-specific installation regulations (e.g. VDE 0100),
- technical connection conditions of the energy suppliers and supply grid operators (e.g. TAB) and
- local conditions.

To ensure that the frost protection function of the heat pump works properly, the heat pump manager must remain connected to the power supply and the flow must be maintained through the heat pump at all times.

The switching contacts of the output relay are interference-suppressed. Therefore, depending on the internal resistance of the measuring instrument, a voltage can also be measured when the contacts are open. However, this will be much lower than the line voltage.

Extra-low voltage is connected to controller terminals N1-J1 to N1-J11; N1-J19 to N1-J20; N1-J23 to N1-J26 and the terminal strips X3. If, due to a wiring error, the line voltage is mistakenly connected to these terminals, the heat pump manager will be destroyed.

⚠ Note

For installation work on the switch box, ensure that the mains cable and signal cables are inserted separately into the switch box. The specially arranged switch box inlets must be used for this purpose (see Fig. 7.3 on page 15).

The mains cables and signal cables must also always be laid separately in the switch box during wiring work.

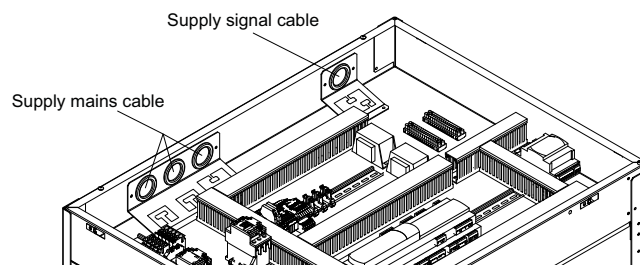

Fig. 7.3: Cable inlet switch box

7.6.2 Electrical installation work

1. The four-core electrical supply cable for the heat pump power part is fed from the heat pump electricity meter into the heat pump via the utility company blocking contactor (if required) (for supply voltage, see heat pump manual).
The mains cable is connected to the heat pump contact plate via terminals X1: L1/L2/L3/PE.

⚠ CAUTION

Ensure that there is a clockwise rotating field: With incorrect wiring the starting of the heat pump is prevented. A corresponding warning is indicated on the display of the heat pump manager (adjust wiring).

An all-pole disconnecting device with a contact gap of at least 3 mm (e.g. utility company blocking contactor or power contactor) and an all-pole circuit breaker with common tripping for all external conductors must be installed in the power supply for the heat pump (tripping current and characteristic in compliance with the device information).

2. The three-core supply cable for the heat pump manager (heating controller N1) is fed into the heat pump. Connection of the control cable to the contact plate of the heat pump via terminal X2: L/N/PE.
The (L/N/PE~230 V, 50 Hz) supply cable for the heat pump manager must have a continuous voltage. For this reason, it should be tapped upstream from the utility company blocking contactor or be connected to the household current, as important protection functions could otherwise be lost during a utility block.
3. The utility company blocking contactor (K22) with main contacts and an auxiliary contact must be designed and provided by the customer in accordance with the heat pump output.
The NO contact of the utility company blocking contactor is looped from the terminal strip X3/G to the plug-in terminal X3/ID3. **CAUTION! Extra-low voltage!**
4. The contactor (K20) for the immersion heater (E10) of mono energy systems (HG2) should be dimensioned according to the radiator output and must be supplied by the customer. It is controlled (230 V AC) by the heat pump manager via terminals X2/N and X2/K20.
5. The contactor (K21) for the flange heater (E9) in the domestic hot water cylinder should be dimensioned according to the radiator output and must be supplied by the customer. It is controlled (230 V AC) by the heat pump manager via terminals X2/N and X2/K21.
6. The contactors mentioned above in points 3, 4 and 5 are installed in the electrical distribution system.
7. All installed electric cables must have permanent wiring.
8. The heat circulating pump (M13) is activated via the contact N1-J13/NO5. The connection points for the pump are X2/M13 and X2/N. When using pumps where the switching capacity exceeds the output, a coupling relay must be interposed.
9. The auxiliary circulating pump (M16) is activated via the contact N1-J16/NO9. The connection points for the pump are X2/M16 and X2/N. A coupling relay is already integrated in this output.
10. The domestic hot water circulating pump (M18) is activated via the contact N1-J13/NO6. The connection points for the pump are X2/M18 and X2/N. When using pumps where the switching capacity exceeds the output, a coupling relay must be interposed.
11. The brine or well pump (M11) is activated via the contact N1-J12/NO3. The connection points for the pump are X2/M11 and X2/N. A coupling relay is already integrated in this output.
12. The return sensor (R2) is integrated in the heat pumps for indoor installation.
The heat pump manager is connected via the following terminals: X3/GND and X3/R2.
13. The external sensor (R1) is connected to terminals X3/GND and X3/R1.
14. The domestic hot water sensor (R3) is included with the domestic hot water cylinder and is connected to terminals GND and X3/R3.

7.6.3 Connection of electronically regulated circulating pumps

Electronically regulated circulating pumps have high starting currents, which may shorten the service life of the heat pump manager. For this reason, a coupling relay is installed or must be installed between the output of the heat pump manager and the electronically regulated circulating pump. This is not necessary if the permissible operating current of 2 A and a maximum starting current of 12 A are not exceeded in the electronically regulated circulating pump or if express approval has been issued by the pump manufacturer.

CAUTION

It is not permitted to connect more than one electronically regulated circulating pump via a relay output.

7.6.4 Circulating pump connection with high performance

In many cases, the supply voltage of the pump is stuck on continuous current when using larger electronically controlled circulating pumps (the manufacturer's information on the pump being used should be taken into consideration). The pump is then generally actuated using the Start/Stop input. This input is operated with extra low voltage from the pump (a link cable is usually inserted in the factory default of the pump). In order to be able to actuate the input, a coupling relay with a floating contact is required. This must be controlled with the pump function of a 230 V relay output of the controller. Due to the extra low voltage to be switched, a suitable relay with the appropriate contact material (gilded) must be selected and integrated on-site.

7.6.5 Frost protection

Regardless of the settings for the heat circulating pumps, they always run in heating and frost protection mode. In systems with multiple heating circuits, the 2nd and 3rd heat circulating pump has the same function.

CAUTION

To ensure that the frost protection function on the heat pump works properly, the heat pump manager must remain connected to the power supply and flow must be maintained through the heat pump at all times.

CAUTION

The primary pump (M11 – responsible for the heat source flow rate) and the secondary pump (M16 – responsible for the warm/cold water flow rate) must always be clamped to the heat pump manager in all cases. This is the only way to ensure the pump flows and returns necessary for operation and to ensure that the necessary safety measures are in place.

8 Commissioning

8.1 General Information

To ensure that commissioning is performed correctly, it should only be carried out by an after-sales service technician (Weishaupt-technician) authorised by the manufacturer. This may be a condition for an additional guarantee .

8.2 Preparation

The following items must be checked prior to commissioning:

- All of the heat pump connections must be installed as described in chapter 7.
- The heat source system and the heating circuit must have been filled and checked.
- The dirt trap must be inserted in the brine inlet of the heat pump.
- All valves that could impair proper flow in the brine and heating circuits must be open.
- The heat pump manager must be adapted to the heating system in accordance with the controller's operating instructions.
- The hydraulic network must be flushed correctly before installing the heat pump. This includes the supply line to the heat pump. Only when flushing is complete can the heat pump be hydraulically integrated.
- The dirt traps present as standard or included for assembly must be inspected between 4 and 8 weeks after the heat pump is commissioned or changes made to the heating system and cleaned if necessary. Further maintenance intervals must be scheduled depending on the level of soiling, which must be defined and carried out by a suitably qualified person.

Special notes for the integration of heat pumps in existing systems (renovations):

The existing heat distribution network (pipe materials, connection types, etc.) and the existing heating systems (e.g. radiators, underfloor heating, etc.) can impact the quality of the water in existing systems. Particularly when welded steel pipes or pipes that are not oxygen diffusion-proof are used, deposits, scaling, silting or similar may be present that can cause damage in the heat pump system. This can result in a total failure of the heat pump. The following measures must be observed to avoid this:

- Compliance with the water properties and water quality
- Flushing of the hydraulic system
- Maintenance interval of the dirt traps.

If silting or ferromagnetic particles are to be expected in the hydraulic network, dirt separators or magnetite separators must be installed on-site before the medium enters the heat pump. The maintenance intervals must be defined by a suitably qualified person.

8.3 Commissioning procedure

The heat pump is commissioned via the heat pump manager.

CAUTION

Start-up must be performed in accordance with the installation and operating instructions of the heat pump manager.

9 Cleaning / maintenance

9.1 Maintenance

To prevent faults due to sediment in the heat exchangers, care must be taken to ensure that no impurities can enter either the heat source system or the heating system. In the event that operating malfunctions due to contamination occur nevertheless, the system should be cleaned as described below.

9.2 Cleaning the heating system

The ingress of oxygen into the heating water circuit may result in the formation of oxidation products (rust), particularly if steel components are used. These enter the heating system via the valves, the circulating pumps and/or plastic pipes. A diffusion-resistant installation is therefore essential, especially with regard to the piping of underfloor heating systems.

Note

We recommend the installation of a suitable corrosion protection system to prevent the formation of deposits (e.g. rust) in the condenser of the heat pump.

Residue from lubricants and sealants may also contaminate the heating water.

In the event of severe contamination leading to a reduction in the performance of the liquefier in the heat pump, the system must be cleaned by a heating technician.

Based on current information, we recommend using a 5 % phosphoric acid solution for cleaning purposes. However, if cleaning needs to be performed more frequently, a 5 % formic acid solution should be used.

In both cases, the cleaning fluid should be at room temperature. We recommend flushing the heat exchanger in the direction opposite to the normal flow direction.

To prevent acidic cleaning agents from entering the heating system circuit, we recommend connecting the flushing device directly to the flow and return of the liquefier of the heat pump.

It is then important that the system be thoroughly flushed using appropriate neutralising agents to prevent any damage from being caused by cleaning agent residue remaining in the system.

Acids must be used with care and the regulations of the employers liability insurance associations must be adhered to.

The instructions of the cleaning agent manufacturer must always be observed.

9.3 Cleaning the heat source system

CAUTION

The supplied dirt trap must be inserted in the heat source inlet of the heat pump to protect the evaporator against the ingress of impurities.

The filter sieve of the dirt trap should be cleaned one day after start-up. Further checks must be set according to the level of dirt. If no more signs of contamination are evident, the filter can be removed to reduce pressure drops.

10 Faults / troubleshooting

This heat pump is a quality product and is designed for trouble-free operation. In the event that a fault should occur, it will be indicated on the heat pump manager display. In this case, consult the "Faults and troubleshooting" page in the operating instructions of the heat pump manager.

If you cannot correct the fault yourself, please contact your after-sales service technician.

CAUTION

Before opening the device, ensure that all circuits are disconnected from the power supply!

After disconnecting the power supply, always wait for at least 5 minutes to allow stored electric charges to dissipate.

CAUTION

Any work on the heat pump may only be performed by authorised and qualified after-sales service technicians.

11 Decommissioning / disposal

Before removing the heat pump, disconnect it from the power source and close all valves. The heat pump must be dismantled by trained personnel.

All environmentally-relevant requirements regarding the recovery, recycling and disposal of materials and components should be observed in accordance with the applicable standards. Particular attention should be paid to the proper disposal of refrigerants and refrigerant oils.

12 Device information

1 Type and order code		WWP S 26 ID	WWP S 35 ID
2 Design			
Heat source		Brine	Brine
2.1 Model		Universal	Universal
2.2 Controller		integrated	integrated
2.3 Thermal energy meter		Integrated	Integrated
2.4 Installation location		Indoors	Indoors
2.5 Performance levels		2	2
3 Operating limits			
3.1 Heating water flow ^{1 2}	°C	20 to 62 ± 2	20 to 62 ± 2
3.2 Brine (heat source) ^{1 2}	°C	-5 to +25	-5 to +25
3.3 Antifreeze		Monoethylene glycol	Monoethylene glycol
3.4 Minimum brine concentration (-13 °C freezing temperature)		25 %	25 %
4 Flow / sound			
4.1 Heating water flow / free compression (max).			
Nominal flow in accordance with EN 14511 at B0...-3 / W35...30	m ³ /h / Pa	4.5 / 59000	6.1 / 44000
at B0...-3 / W45...40	m ³ /h / Pa	4.4 / 62000	5.7 / 44000
at B0...-3 / W55...47	m ³ /h / Pa	2.7 / 92000	3.5 / 73000
Minimum heating water flow	m ³ /h / Pa	2.7 / 92000	3.5 / 73000
4.2 Brine flow rate / free compression (max).			
Nominal flow in accordance with EN 14511 at B0...-3 / W35...30	m ³ /h / Pa	6.4 / 31000	8.2 / 64000
at B0...-3 / W45...40	m ³ /h / Pa	5.6 / 35000	7.3 / 72000
at B0...-3 / W55...47	m ³ /h / Pa	4.9 / 48000	6.4 / 82000
Minimum brine flow rate	m ³ /h / Pa	4.9 / 48000	6.4 / 82000
4.3 Sound power level according to EN 12102	dB(A)	57	58
4.4 Sound pressure level at a distance of 1 m ³	dB(A)	41	42
5 Dimensions, weight and filling quantity			
5.1 Device dimensions ⁴	H x W x L mm	880 x 1000 x 800	880 x 1000 x 800
5.2 Weight of the transportable unit(s) incl. packaging	kg	275	315
5.3 Device connections for heating	inches	G 1½" external thread	G 1½" external thread
5.4 Device connections for heat source	Inches	G 1½" external thread	G 1½" external thread
5.5 Refrigerant / total filling weight	type/kg	R410A / 8.4	R410A / 10.9
5.6 GWP value / CO ₂ equivalent	--- / t	2088 / 18	2088 / 23
5.7 Refrigeration circuit hermetically sealed		yes	yes
5.8 Lubricant / total filling quantity	type/litres	Polyolester (POE)/2.9	Polyolester (POE)/4.2
5.9 Volume of heating water in device	Litres	7	9
5.10 Volume of heat transfer medium in device	Litres	7	9
6 Electrical connection			
6.1 Supply voltage / fuse protection / RCD-Type		3~/PE 400 V (50 Hz) / C 20A / A	3~/PE 400 V (50 Hz) / C 32A / A
6.2 Control voltage / fuse protection / RCD-Type		1~/N/PE 230 V (50 Hz) / C 13A / A	1~/N/PE 230 V (50 Hz) / C 13A / A
6.3 Degree of protection according to EN 60 529		IP 21	IP 21
6.4 Starting current with soft starter	A	23	30
6.5 Nominal power consumption B0 W35 / max. power consumption ⁵	kW	5.45 / 10.0	7.25 / 14.5
6.6 Nominal current B0 W35 / cos φ	A / ---	9.83 / 0.8	13.08 / 0.8
6.7 Power consumption of compressor protection (per compressor)	W	70 / thermostatically controlled	70 / thermostatically controlled
6.8 Power consumption of pumps	kW	up to 0.35	up to 0.5

7 Complies with the European safety regulations	6		6		
8 Additional model features					
8.1 Water in device is protected against freezing⁷	Yes		Yes		
8.2 Max. operating overpressure (heat source/heat sink) bar	3.0		3.0		
9 Heat output / COP					
9.1 Heat output / coefficient of performance (COP)^{5 8}	EN 14511		EN 14511		
	Performance level	1	2	1	2
	at B-5 / W45 kW / ---	11.5 / 3.6	22.5 / 3.5	15.1 / 3.5	9.2 / 3.3
	at B0 / W55 kW / ---	12.4 / 3.1	24.7 / 3.1	16.8 / 3.2	32.1 / 3.0
	at B0 / W45 kW / ---	13.2 / 4.1	25.4 / 3.8	17.3 / 4.0	33.1 / 3.7
	at B0 / W35 kW / ---	13.7 / 5.1	26.7 / 4.9	18.4 / 5.2	34.8 / 4.8

1. If necessary, the operating range can be extended to a brine inlet temperature of -10 °C. In this case, the minimum brine concentration must be adjusted to 30%. (Freezing temperature -17 °C)
For brine inlet temperatures of -10 °C to -5 °C, flow temperature increasing from 50 °C to 60 °C.
For brine inlet temperatures of -5 °C to 0°C, flow temperature increasing from 60 °C to 62 °C.
2. Operation is possible at brine inlet temperatures of up to +35 °C. For brine inlet temperatures of +25 °C to 35 °C, flow temperature decreasing from 62 °C to 58 °C.
3. The specified sound pressure level corresponds to the operating noise of the heat pump in heating operation at 55 °C flow temperature. The specified sound pressure level represents the free sound area level. The measured value can deviate by up to 16 dB(A), depending on the installation location.
4. Note that additional space is required for pipe connections, operation and maintenance.
5. These data indicate the size and capacity of the system according to EN 14511. For an analysis of the economic and energy efficiency of the system, the bivalence point and regulation should be taken into consideration. These specifications can only be achieved with clean heat exchangers. Information on maintenance, commissioning and operation can be found in the respective sections of the installation and operating instructions. The specified values, e.g. B0 / W55, have the following meaning: Heat source temperature 0 °C and heating water flow temperature 55 °C.
6. See CE declaration of conformity
7. The heat circulating pump and the heat pump manager must always be ready for operation.
8. The coefficients of performance are valid with the circulating pumps included in the scope of supply.

Appendix

1	Dimension Drawings	II
1.1	Dimension Drawing WWP S 26 ID - WWP S 35 ID	II
2	Diagrams	III
2.1	Characteristic Curves WWP S 26 ID	III
2.2	Characteristic Curves WWP S 35 ID	IV
2.3	Operating limits diagram.....	V
3	Circuit Diagrams	VI
3.1	Control WWP S 26 ID.....	VI
3.2	Control WWP S 26 ID.....	VII
3.3	Load WWP S 26 ID.....	VIII
3.4	Connection Plan WWP S 26 ID	IX
3.5	Connection Plan WWP S 26 ID	X
3.6	Legend WWP S 26 ID.....	XI
3.7	Control WWP S 35 ID.....	XIII
3.8	Control WWP S 35 ID.....	XIV
3.9	Load WWP S 35 ID.....	XV
3.10	Connection Plan WWP S 35 ID	XVI
3.11	Connection Plan WWP S 35 ID	XVII
3.12	Legend WWP S 35 ID.....	XVIII
4	Hydraulic integration diagram	XX
4.1	Sample system diagram.....	XX

1 Dimension Drawings

1 Dimension Drawings

1.1 Dimension Drawing WWP S 26 ID - WWP S 35 ID

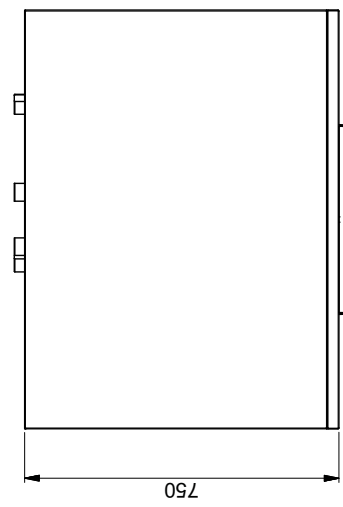
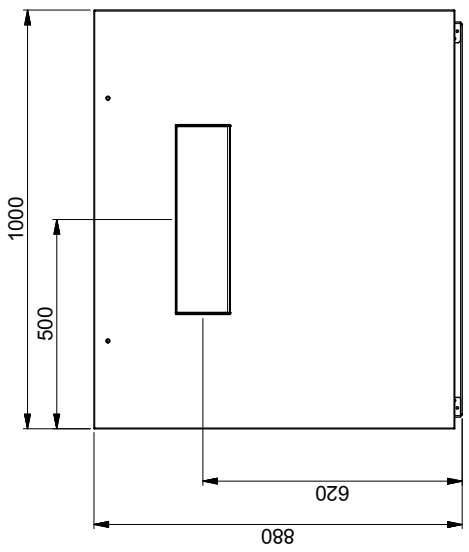
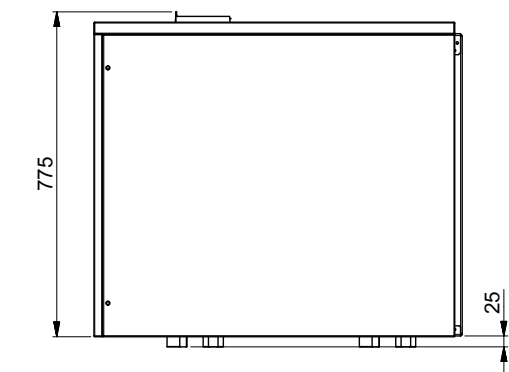
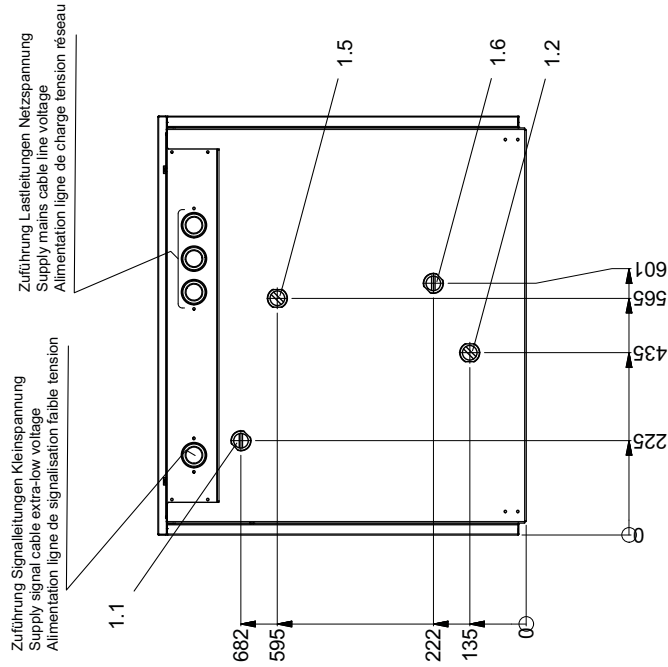

1.1 Heizungsvorlauf Ausgang aus Wärmepumpe G 1 1/2" A	Heating water flow Heat pump outlet G 1 1/2" external thread	Aller eau de chauffage Sortie de la PAC Filetage extérieur 1 1/2"
1.2 Heizungsrücklauf Eingang in Wärmepumpe G 1 1/2" A	Heating water return flow Heat pump inlet G 1 1/2" external thread	Retour eau de chauffage Entrée dans la PAC Filetage extérieur 1 1/2"
1.5 Wärmequelle Eingang in Wärmepumpe G 1 1/2" A	Heat source Heat pump inlet G 1 1/2" external thread	Source de chaleur Entrée dans la PAC Filetage extérieur 1 1/2"
1.6 Wärmequelle Ausgang aus Wärmepumpe G 1 1/2" A	Heat source Heat pump outlet G 1 1/2" external thread	Source de chaleur Sortie de la PAC Filetage extérieur 1 1/2"

2 Diagrams

2.1 Characteristic Curves WWP S 26 ID

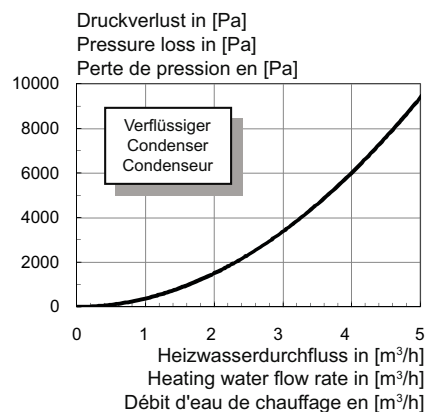
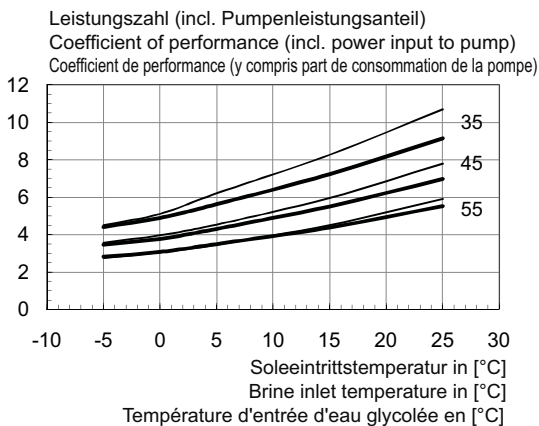
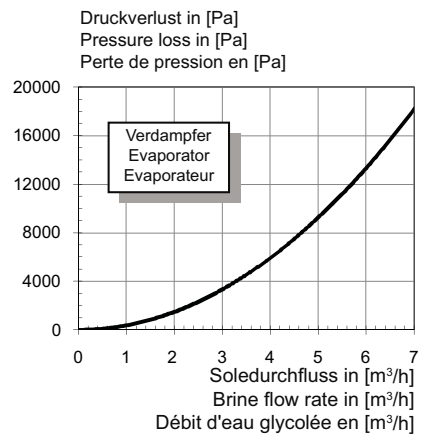
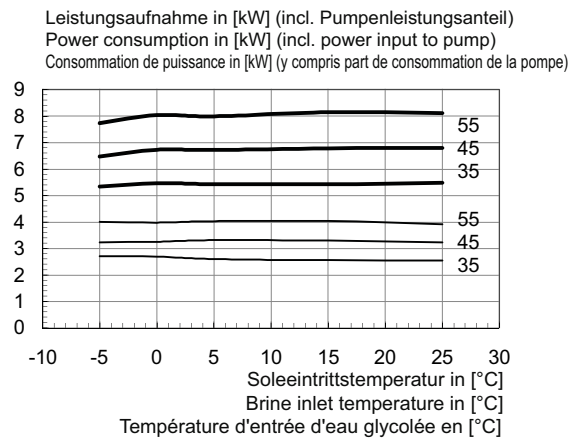
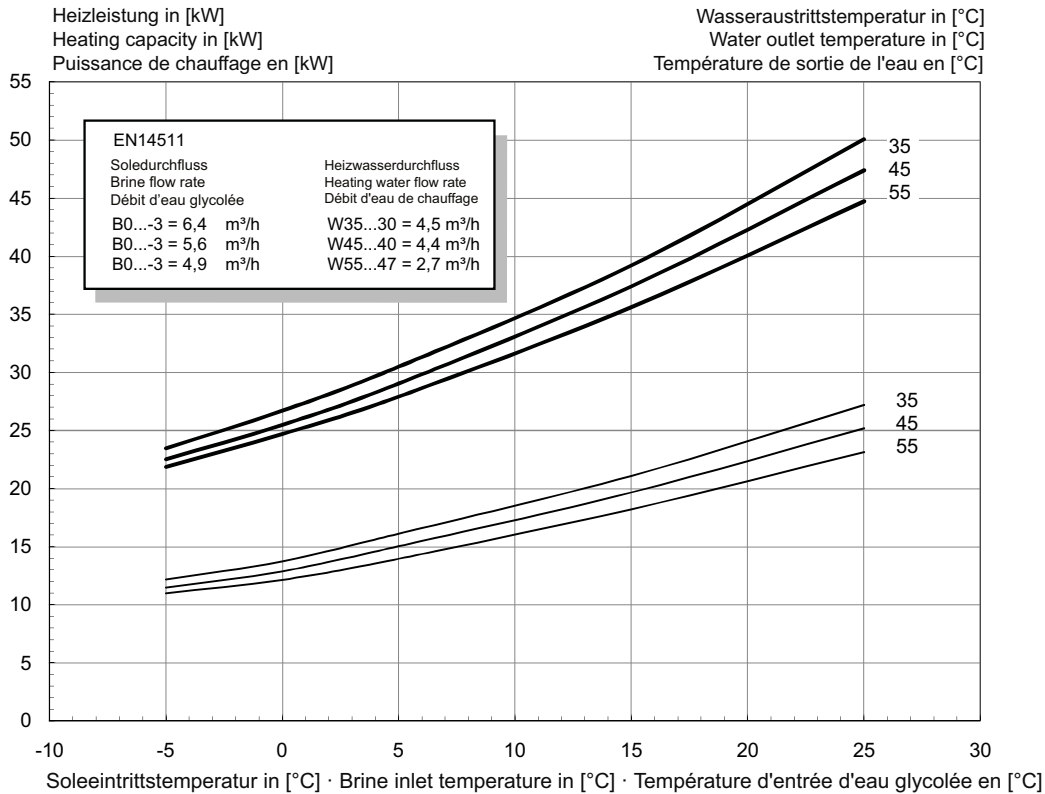

2.2 Characteristic Curves WWP S 35 ID

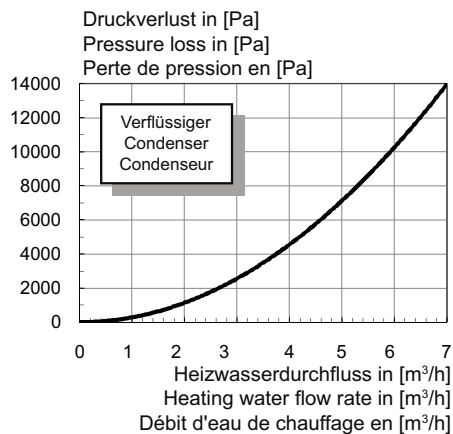
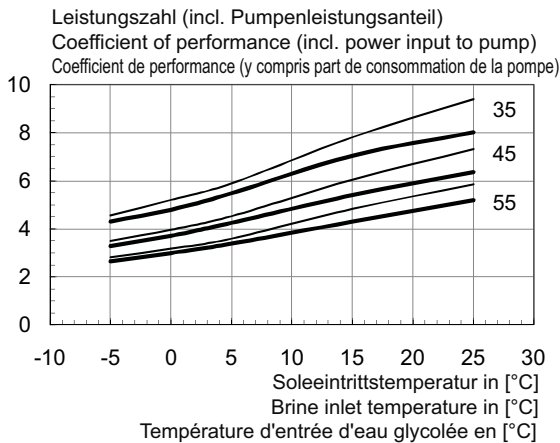
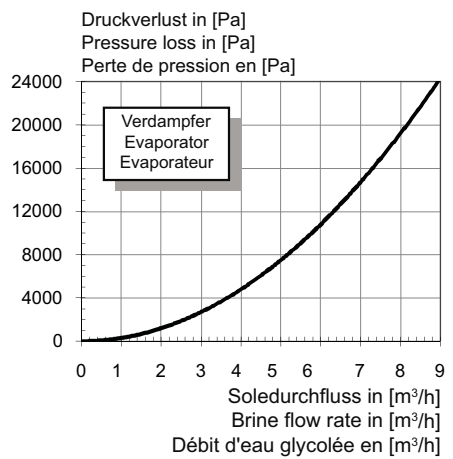
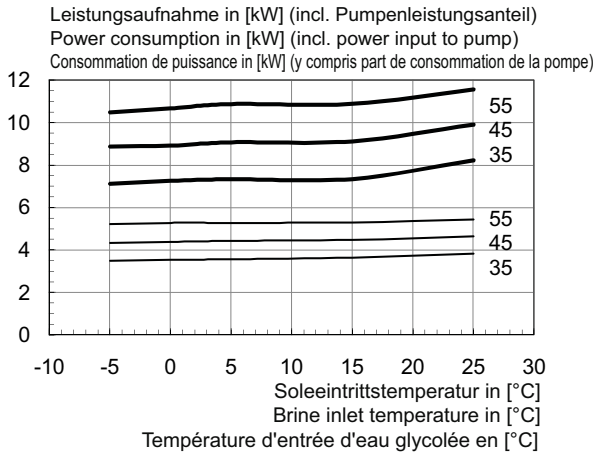
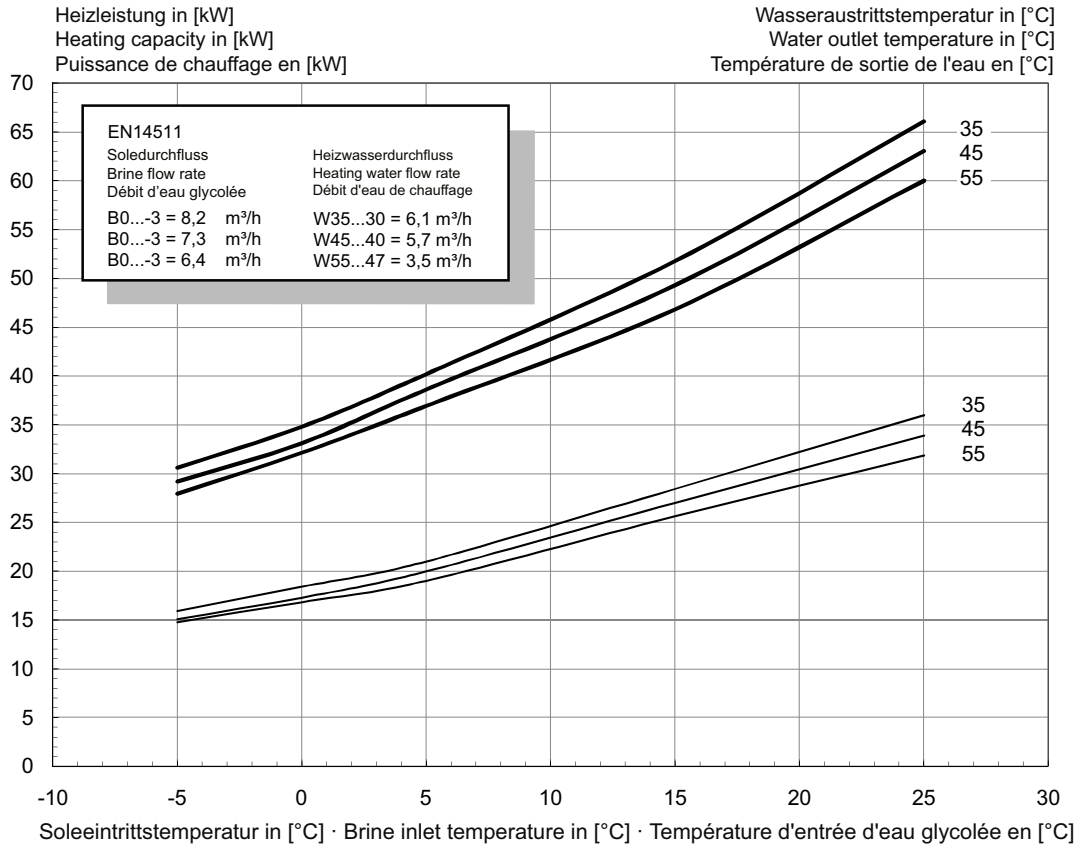

2.3 Operating limits diagram

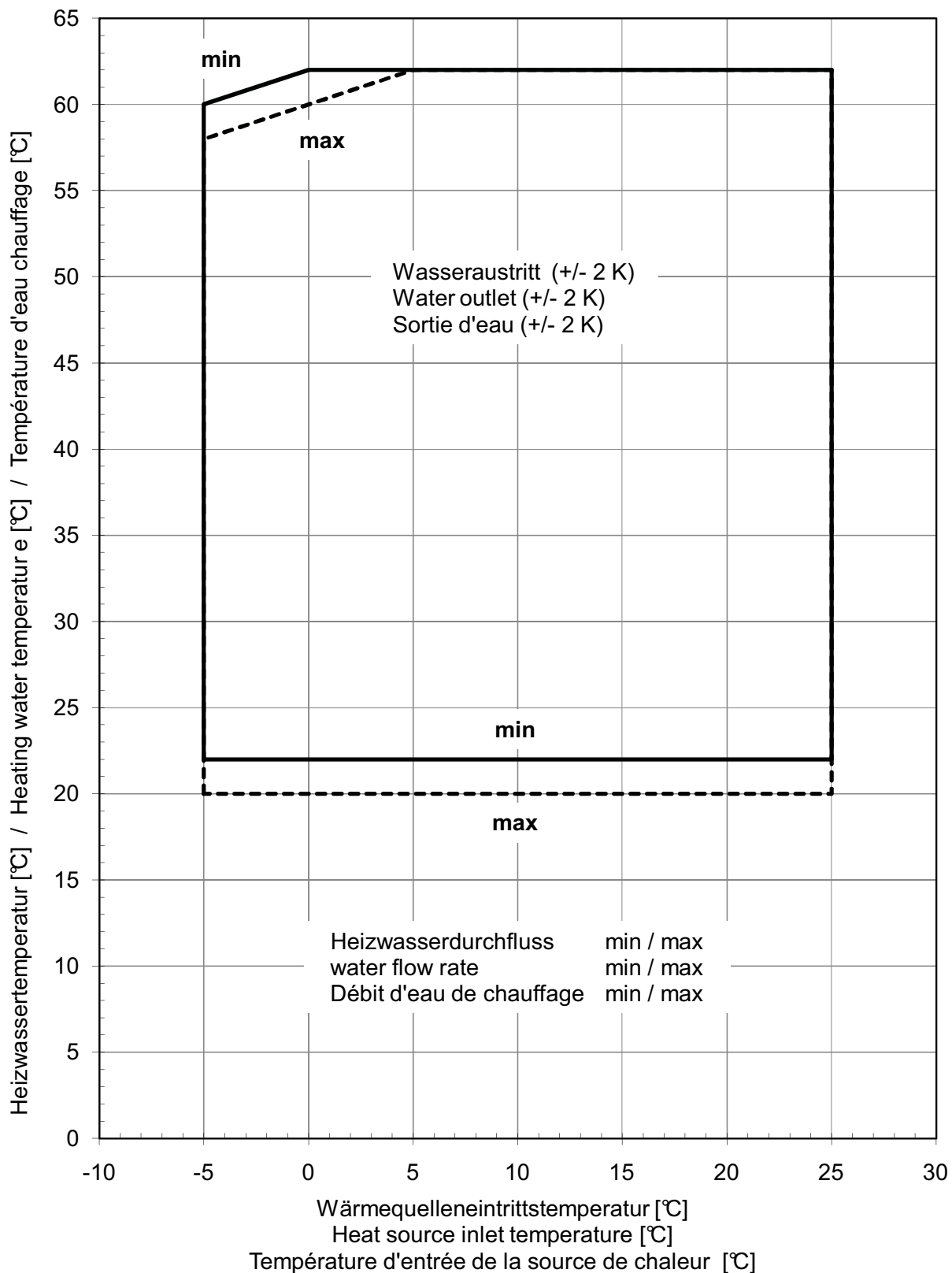

3 Circuit Diagrams

3 Circuit Diagrams

3.1 Control WWP S 26 ID

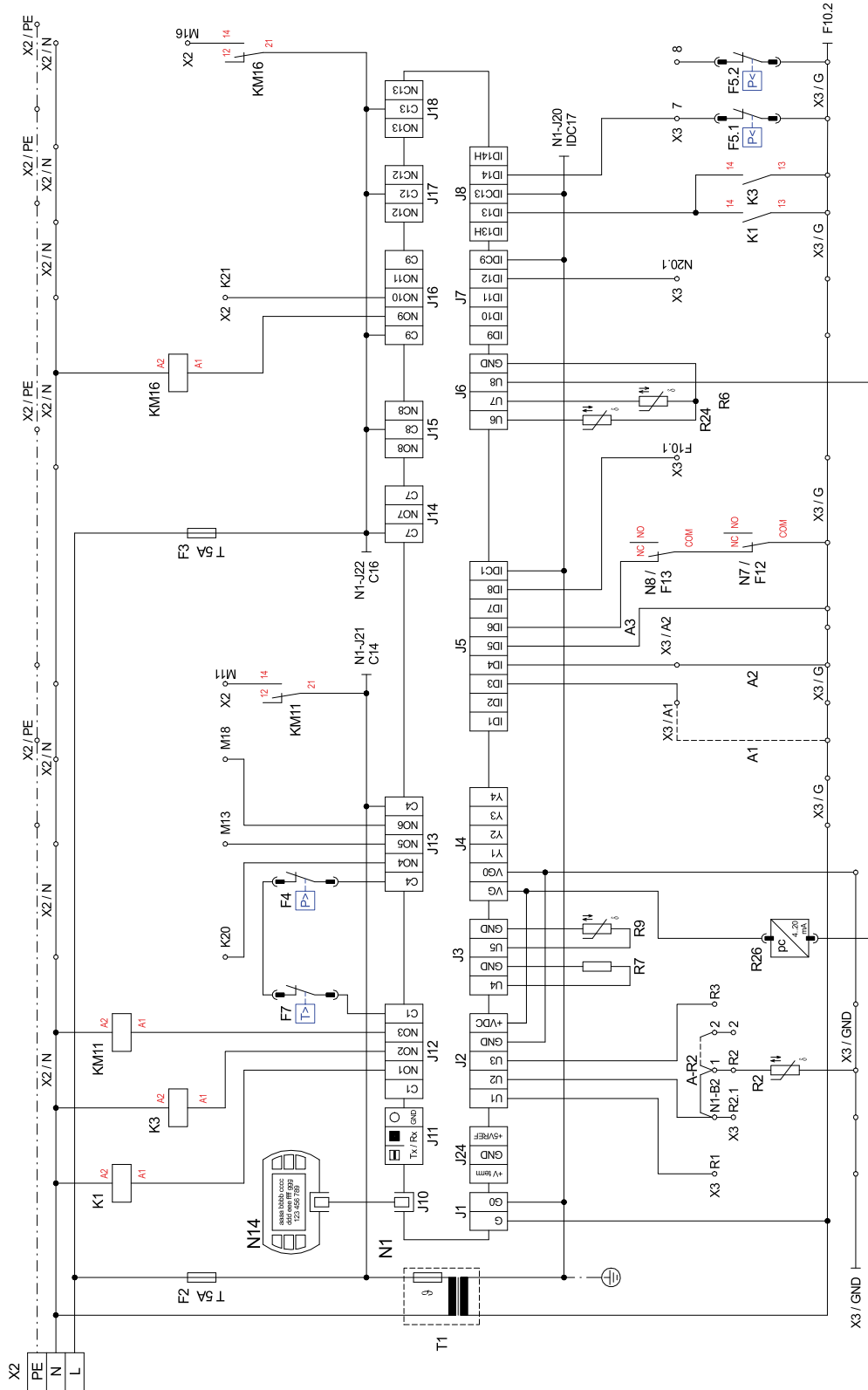

3.2 Control WWP S 26 ID

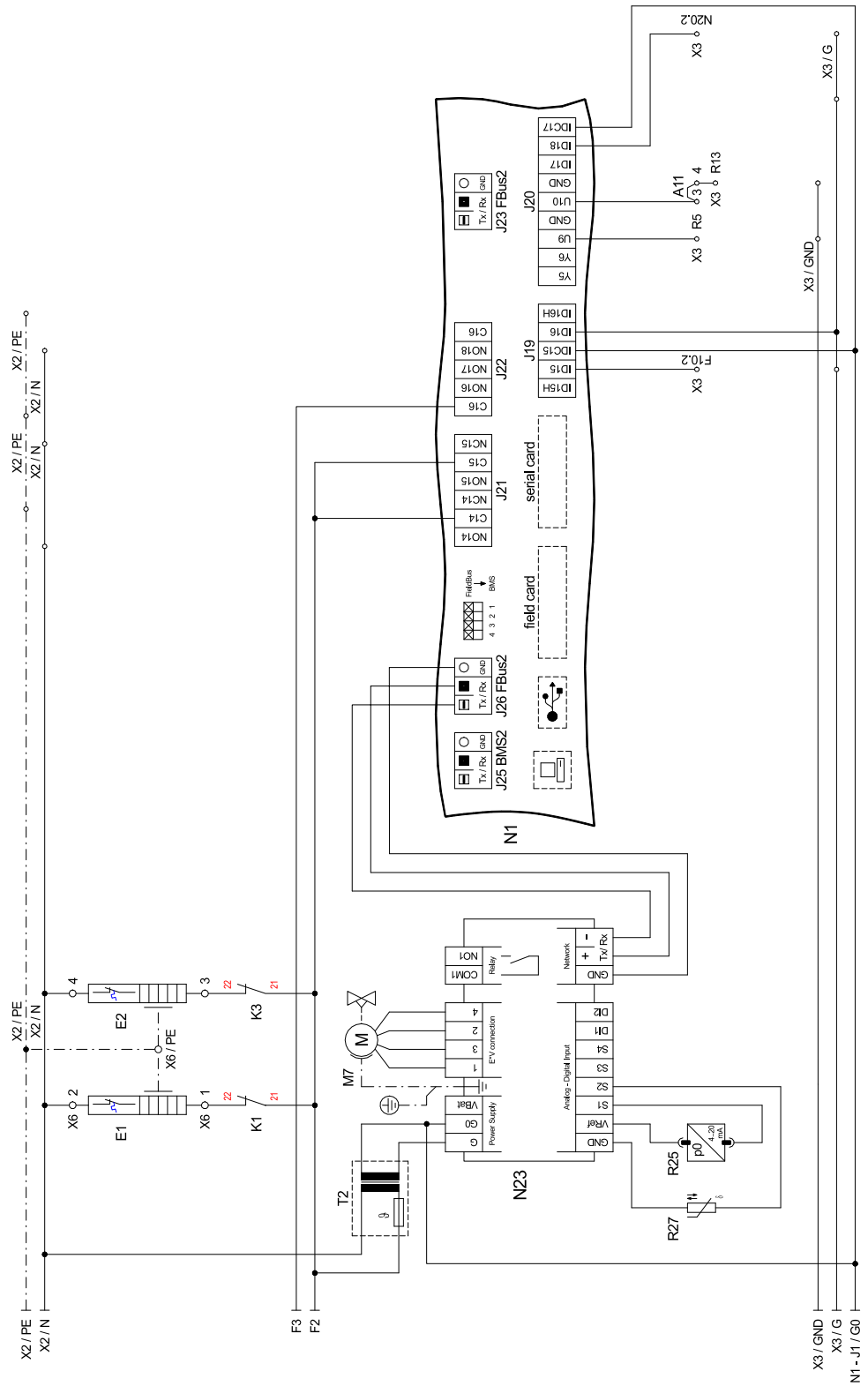

3.3 Load WWP S 26 ID

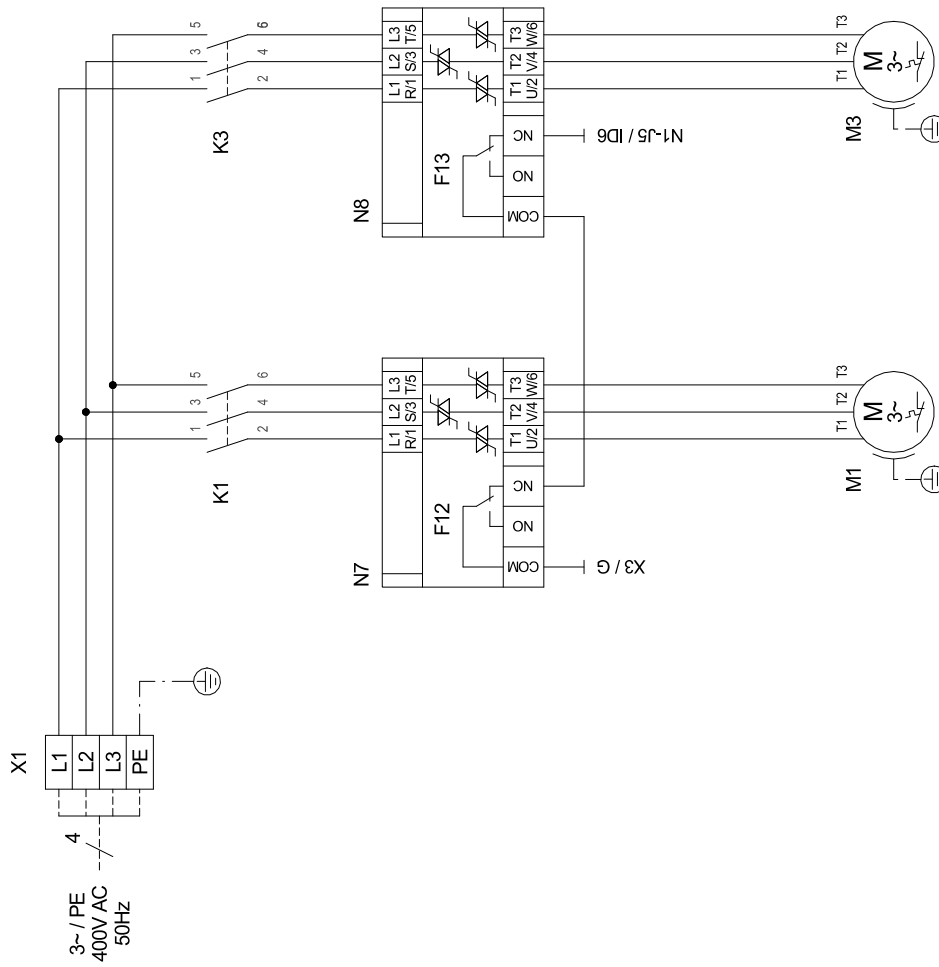

3 Circuit Diagrams

3.4 Connection Plan WWP S 26 ID

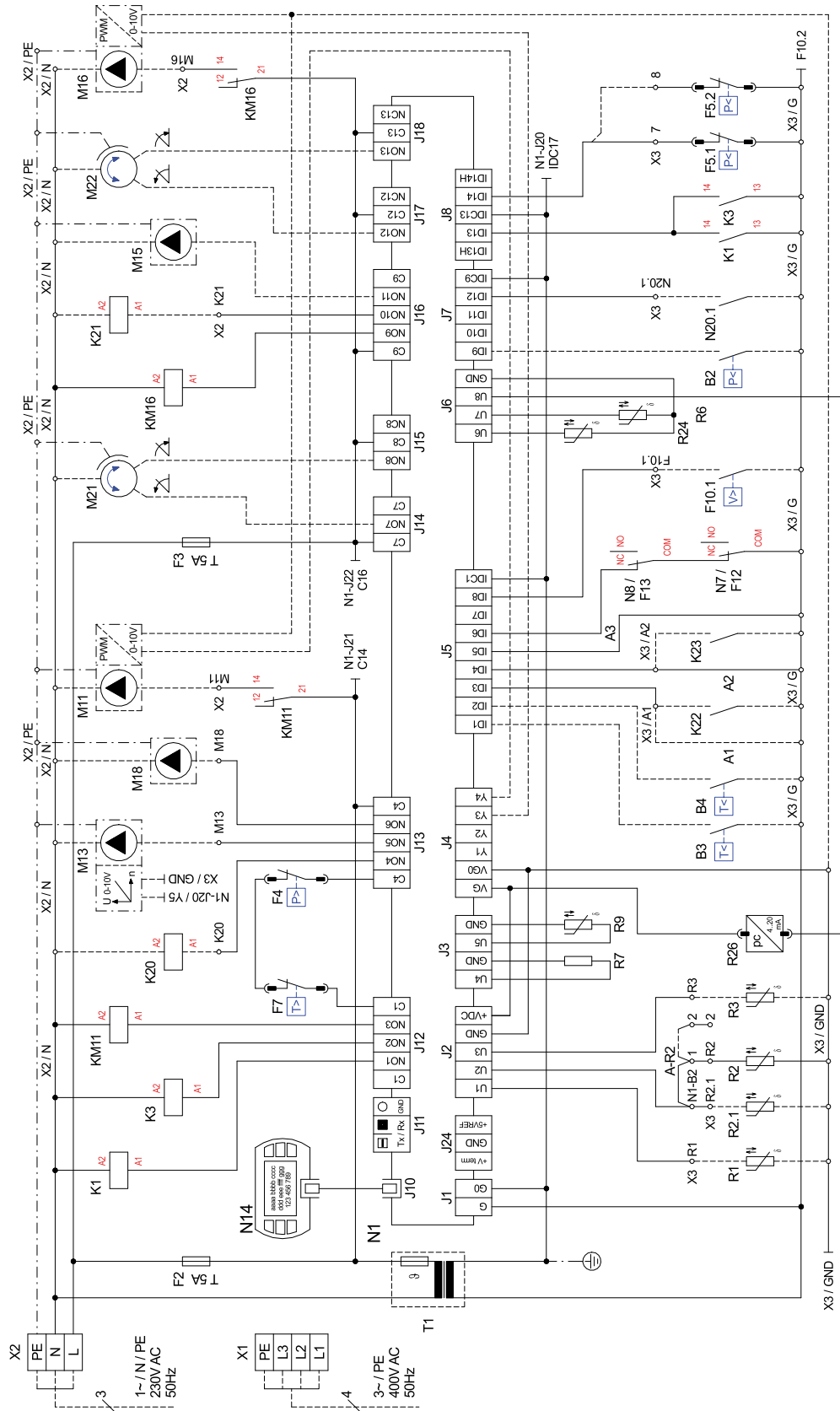

3.5 Connection Plan WWP S 26 ID

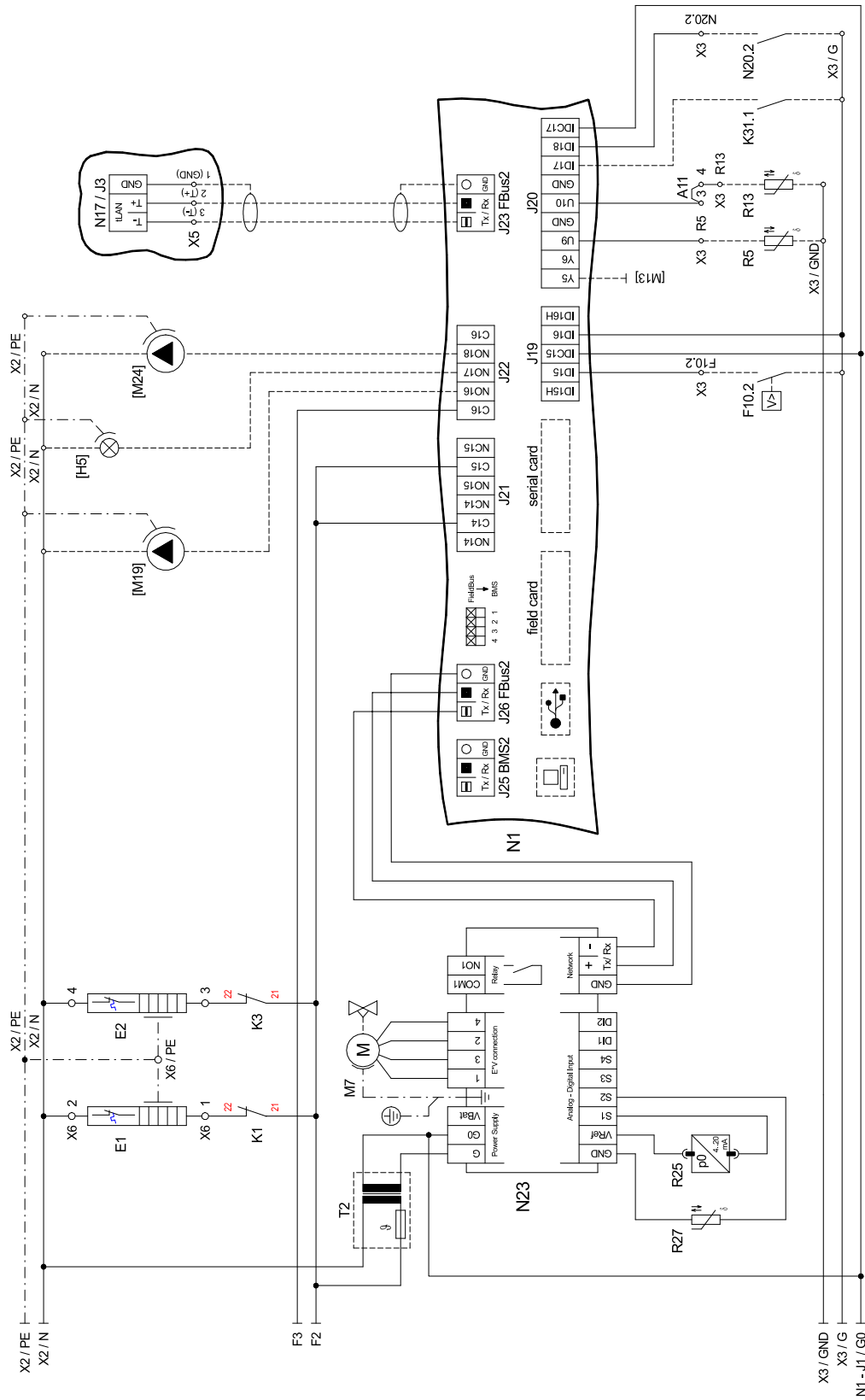

3 Circuit Diagrams

3.6 Legend WWP S 26 ID

A1	Brücke EVU-Sperre, muss eingelegt werden, wenn kein EVU-Sperrschütz vorhanden ist (Kontakt offen = EVU-Sperre)	Utility block (EVU) bridge must be inserted if no utility blocking contactor is present (contact open = utility block).	Pont de blocage de la société d'électricité, à insérer en absence de contacteur de blocage de la société d'électricité (contact ouvert = blocage de la société d'électricité)
A2	Brücke Sperre: muss entfernt werden, wenn der Eingang genutzt wird (Eingang offen = WP gesperrt)	Block bridge: Must be removed when the input is being used (input open = HP blocked).	Pont de blocage : à retirer si l'entrée est utilisée (entrée ouverte = pompe à chaleur bloquée)
A3	Brücke Störung M11: muß entfernt werden, wenn der Eingang genutzt wird (Eingang offen = Störung M11)	M11 link cable fault: must be removed when the input is being used (input open = M11 fault)	Pont défaut M11 : à retirer si l'entrée est utilisée (entrée ouverte = défaut M11)
A - R2	Brücke Rücklauffühler: - muss versetzt werden, wenn doppelt differenzdruckloser Verteiler und „Heizkreisumkehrventil“ verwendet wird. Neue Klemmstellen: X3 / 1 und X3 / 2	Return sensor bridge: - Must be moved when a dual differential pressureless manifold and a "heating circuit reversing valve" are used. New terminal connections: X3/1 and X3/2	Pont sonde sur circuit de retour : - à déplacer si le distributeur double sans pression différentielle et la « vanne d'inversion du circuit de chauffage » sont utilisés. Nouveaux emplacements de borne : X3 / 1 et X3 / 2
B2*	Niederdruckssostat Primärkreis	Low-pressure switch, primary circuit	Pressostat basse pression circuit primaire
B3*	Thermostat Warmwasser	Hot water thermostat	Thermostat eau chaude
B4*	Thermostat Schwimmbadwasser	Swimming pool water thermostat	Thermostat eau de piscine
E1	Ölsumpfheizung M1	Oil sump heater M1	Chauffage à carter d'huile M1
E2	Ölsumpfheizung M2	Oil sump heater M2	Chauffage à carter d'huile M2
E9*	Tauchheizkörper (Warmwasser)	Immersion heater for hot water	Résistance immergée eau chaude sanitaire
E10*	2. Wärmeerzeuger	2nd heat generator	2ème générateur de chaleur
F2	Sicherung für Steckklemmen J12; J13 und J21 5x20 / 5,0AT	Fuse for plug-in terminals J12; J13 and J21 5x20 / 5.0AT	Fusible pour bornes enfichables J12 ; J13 et J21 5x20 / 5,0AT
F3	Sicherung für Steckklemmen J14 bis J18 und J22 5x20 / 5,0AT	Fuse for plug-in terminals J14 to J18 and J22 5x20 / 5.0AT	Fusible pour bornes enfichables J14 à J18 et J22 5x20 / 5,0AT
F4	Hochdruckpressostat	High-pressure switch	Pressostat haute pression
F5.1	Niederdruckpressostat Sole/Wasser-Wärmepumpe	Low-pressure switch brin-to water heat pump	Pressostat basse pression pompe à chaleur eau glycolée/eau
F5.2	Niederdruckpressostat Wasser/Wasser-Wärmepumpe	Low-pressure switch water-to water heat pump	Pressostat basse pression pompe à chaleur eau/eau
F7	Heißgasthermostat	Hot gas thermostat	Thermostat gaz chaud
F10.1*	Durchflussschalter Primärkreis	Flow rate switch for primary circuit	Commutateur de débit circuit primaire
F10.2*	Durchflussschalter Sekundärkreis	Flow rate switch for secondary circuit	Commutateur de débit circuit secondaire
F12	Störmeledekontakt N7	Fault signaling contact N7	Contact de signalisation de défauts N7
F13	Störmeledekontakt N8	Fault signaling contact N8	Contact de signalisation de défauts N8
[H5]*	Leuchte Störferrnanzeige	Remote fault indicator lamp	Témoin de télé-détection de pannes
J1	Spannungsversorgung	Voltage supply	Alimentation en tension
J2-3	Analogeingänge	Analogue inputs	Entrées analogiques
J4	Analogausgänge	Analogue outputs	Sorties analogiques
J5	Digitaleingänge	Digital inputs	Entrées numériques
J6	Analogausgänge	Analogue outputs	Sorties analogiques
J7-8	Digitaleingänge	Digital inputs	Entrées numériques
J9	frei	free	libre
J10	Bedienteil	Control panel	Unité de commande
J11	frei	free	libre
J12-J18	230 V AC - Ausgänge	230 V AC outputs	Sorties 230 V AC
J19	Digitaleingänge	Digital inputs	Entrées numériques
J20	Analogausgänge; Analogeingänge, Digitaleingänge	Analogue outputs; Analogue inputs, Digital inputs	Sorties analogiques, entrées analogiques, entrées numériques
J21-22	Digitalausgänge	Digital outputs	Sorties numériques
J23	Bus-Verbindung extern	Bus connection external	Raccordement externe au bus
J24	Spannungsversorgung für Komponenten	Power supply for components	Alimentation en tension des composants
J25	Schnittstelle	Interface	Interface
J26	Bus-Verbindung intern	Bus connection internal	Raccordement interne au bus
K1	Schütz M1	Contactor M1	Contacteur M1
K3	Schütz M3	Contactor M3	Contacteur M3
K20*	Schütz E10	Contactor E10	Contacteur E10
K21*	Schütz E9	Contactor E9	Contacteur E9
K22*	EVU-Sperrschütz	Utility blocking contactor	Contacteur de coupure du fournisseur d'énergie
K23*	Hilfsrelais für Sperreingang	Auxiliary relay for disable contactor	Relais auxiliaire pour entrée du contacteur de blocage
K31.1*	Anforderung Zirkulation Warmwasser	Domestic hot water circulation request	Demande circulation ECS
KM11	Hilfsrelais M11	Auxiliary relay M11	Relais auxiliaire M11
KM16	Hilfsrelais M16	Auxiliary relay M16	Relais auxiliaire M16
M1	Verdichter 1	Compressor 1	Compresseur 1
M3	Verdichter 2	Compressor 2	Compresseur 2
M7	Stellmotor für Expansionsventil	Actuator for expansion valve	Servomoteur pour détendeur
M11*	Primärkreispumpe	Primary circuit pump	Pompe circuit primaire
M13*	Heizungsumwälzpumpe	Heat circulating pump	Circulateur de chauffage
M15*	Heizungsumwälzpumpe 2. Heizkreis	Heat circulating pump for heating circuit 2	Circulateur de chauffage pour le 2e circuit de chauffage
M16*	Zusatzumwälzpumpe	Auxiliary circulating pump	Circulateur supplémentaire
M18*	Warmwasserladepumpe	Hot water loading pump	Pompe de charge eau chaude sanitaire
[M19]*	Schwimmbadwasserumwälzpumpe	Swimming pool circulating pump	Circulateur de la piscine
M21*	Mischer Hauptkreis oder 3. Heizkreis	Mixer for main circuit or heating circuit 3	Mélangeur circuit principal ou 3ème circuit de chauffage

3 Circuit Diagrams

M22*	Mischer 2. Heizkreis	Mixer for heating circuit 2	Mélangeur 2e circuit de chauffage
[M24]*	Zirkulationspumpe Warmwasser	Domestic hot water circulating pump	Pompe de circulation eau chaude sanitaire
N1	Regeleinheit	Control unit	Unité de régulation
N7	Sanftanlaufsteuerung M1	Soft start control M1	Commande de démarrage progressif M1
N8	Sanftanlaufsteuerung M3	Soft start control M3	Commande de démarrage progressif M3
N14	Bedienteil	Control panel	Unité de commande
N17*	pCOe-Modul	pCOe module	Module pCOe
N20*	Wärmemengenzähler	Thermal energy meter	Compteur de chaleur
N23	Ansteuerung elektronisches Expansionsventil E*V connection (1 = grün; 2 = gelb; 3 = braun; 4 = weiß)	Control for electronic expansion valve E*V connection (1=green; 2=yellow; 3=brown; 4=white)	Commande détendeur électronique connexion E*V (1=vert ; 2=jaune ; 3=marron ; 4=blanc)
R1*	Außenfühler	External sensor	Sonde extérieure
R2	Rücklauffühler Heizkreis	Return sensor for heating circuit	Sonde de retour circuit de chauffage
R2.1*	Rücklauffühler Heizkreis im doppelt differenzdrucklosen-Verteiler	Return sensor for heating circuit in dual differential pressureless manifold	Sonde de retour circuit de chauffage dans le distributeur double sans pression différentielle
R3*	Warmwasserfühler	Hot water sensor	Sonde d'eau chaude
R5*	Fühler 2. Heizkreis	Sensor heating circuit 2	Sonde pour 2e circuit de chauffage
R6	Vorlauffühler Primärkreis	Flow sensor for primary circuit	Sonde aller circuit primaire
R7	Codierwiderstand	Coding resistor	Résistance de codage
R9	Vorlauffühler Heizkreis	Flow sensor for heating circuit	Sonde aller circuit de chauffage
R13*	Fühler regenerativ, Raumfühler, Fühler 3. Heizkreis	Renewable sensor, room sensor, sensor for heating circuit 3	Sonde mode régénératif, sonde d'ambiance, sonde 3ème circuit de chauffage
R20*	Schwimmbadfühler	Swimming pool sensor	Sonde de piscine
R24	Rücklauffühler Primärkreis	Return sensor, primary circuit	Sonde retour circuit primaire
R25	Drucksensor Kältekreis - Niederdruck pO	Pressure sensor for refrigerating circuit - low pressure pO	Capteur de pression circuit réfrigérant - basse pression pO
R26	Drucksensor Kältekreis - Hochdruck pc	Pressure sensor for refrigerating circuit - high pressure pc	Capteur de pression circuit réfrigérant - haute pression pc
R27	Sauggasfühler	Suction gas sensor	Sonde de gaz d'aspiration
T1	Sicherheitstransformator 230 / 24 V AC	Safety transformer 230 / 24 V AC	Transformateur de sécurité 230 / 24 V AC
T2	Sicherheitstransformator 230 / 24 V AC	Safety transformer 230 / 24 V AC	Transformateur de sécurité 230 / 24 V AC
X1	Klemmleiste Einspeisung	Terminal strip, infeed	Alimentation bornier
X2	Klemmleiste Spannung = 230 V AC	Terminal strip voltage = 230 V AC	Tension bornier = 230 V AC
X3	Klemmleiste Kleinspannung < 25 V AC	Terminal strip, extra-low voltage < 25 V AC	Faible tension bornier < 25 V AC
X6	Klemmleiste Ölsumpfheizung	Oil sump heater terminal strip	Bornier chauffage à carter d'huile
XF5	Klemmleiste F5.x	Terminal strip F5.x	Bornier F5.x
*	Bauteile sind bauseits anzuschließen / beizustellen	Components must be connected / supplied by the customer	Les pièces sont à raccorder / à fournir par le client
[]	Flexible Beschaltung - siehe Vorkonfiguration (Änderung nur durch Kundendienst!)	Flexible switching - see pre-configuration (changes by after-sales service only!)	Commande flexible - voir pré-configuration (modification uniquement par le SAV !)
-----	werksseitig verdrahtet	Wired ready for use	câblé en usine
-----	bauseits bei Bedarf anzuschließen	To be connected by the customer as required	À raccorder par le client au besoin

⚠ ACHTUNG

An den Steckklemmen N1-J1 bis J11, J19, J20; J23 bis J26 und der Klemmleisten X3, liegt Kleinspannung an. Auf keinen Fall darf hier eine höhere Spannung angelegt werden.

⚠ ATTENTION

Plug-in terminals N1-J1 to J11, J19, J20, J23 to J26 and terminal strip X3 are connected to extra-low voltage. A higher voltage must on no account be connected.

⚠ ATTENTION !

Une faible tension est appliquée aux bornes enfichables N1-J1 à J11, J19, J20, J23 à J26 et au bornier X3. Ne jamais appliquer une tension plus élevée.

3 Circuit Diagrams

3.7 Control WWP S 35 ID

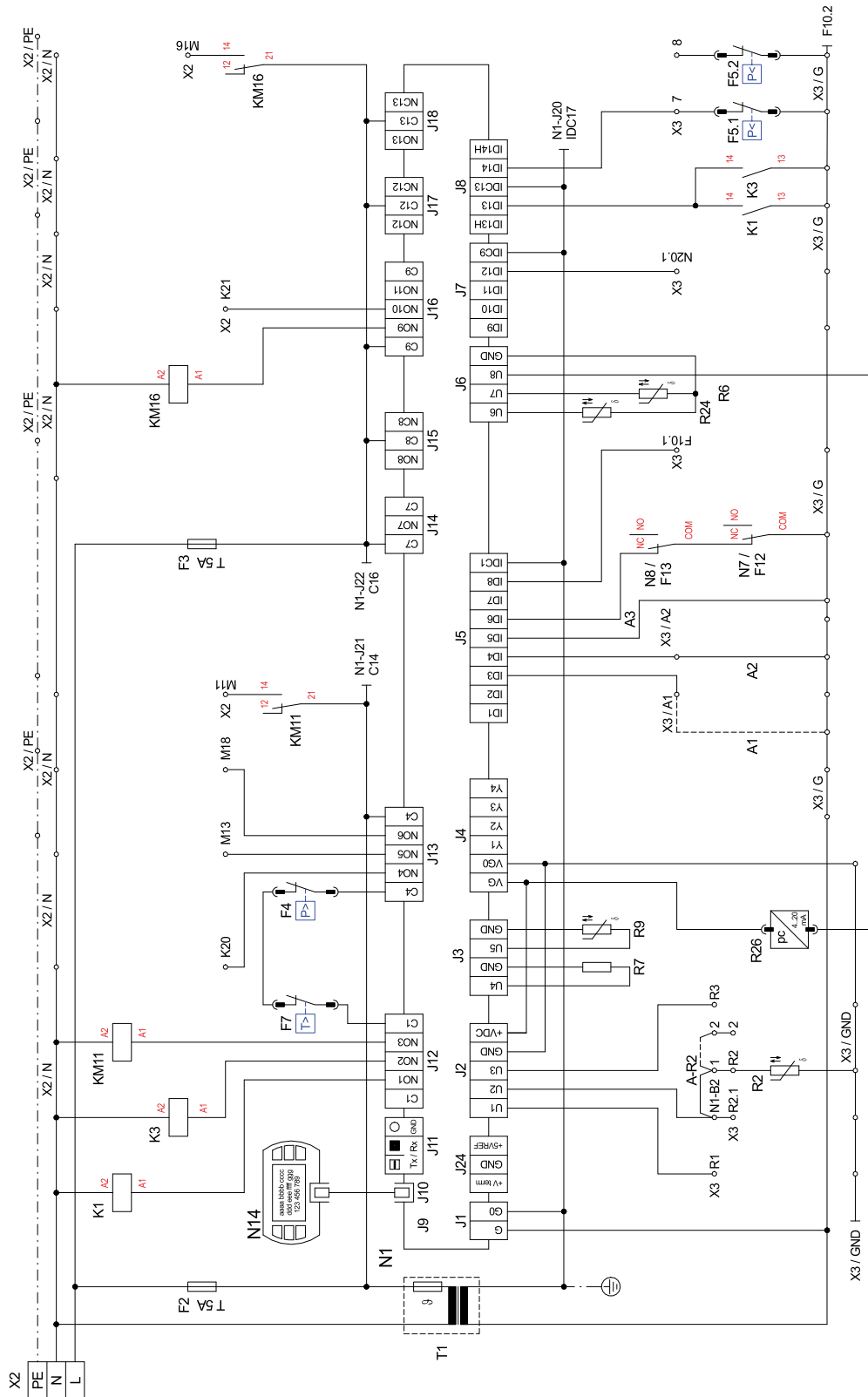

3 Circuit Diagrams

3.8 Control WWP S 35 ID

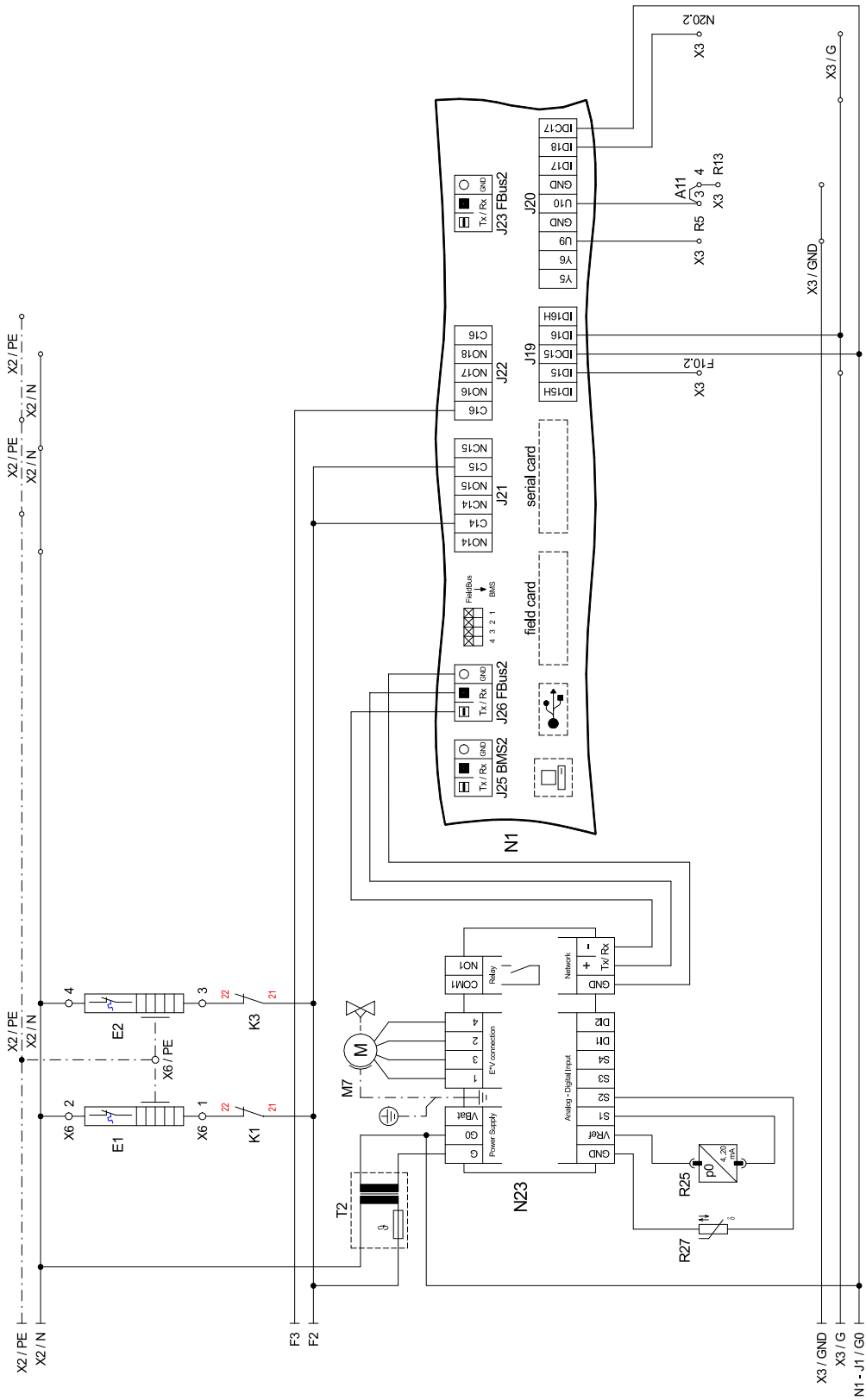

3.9 Load WWP S 35 ID

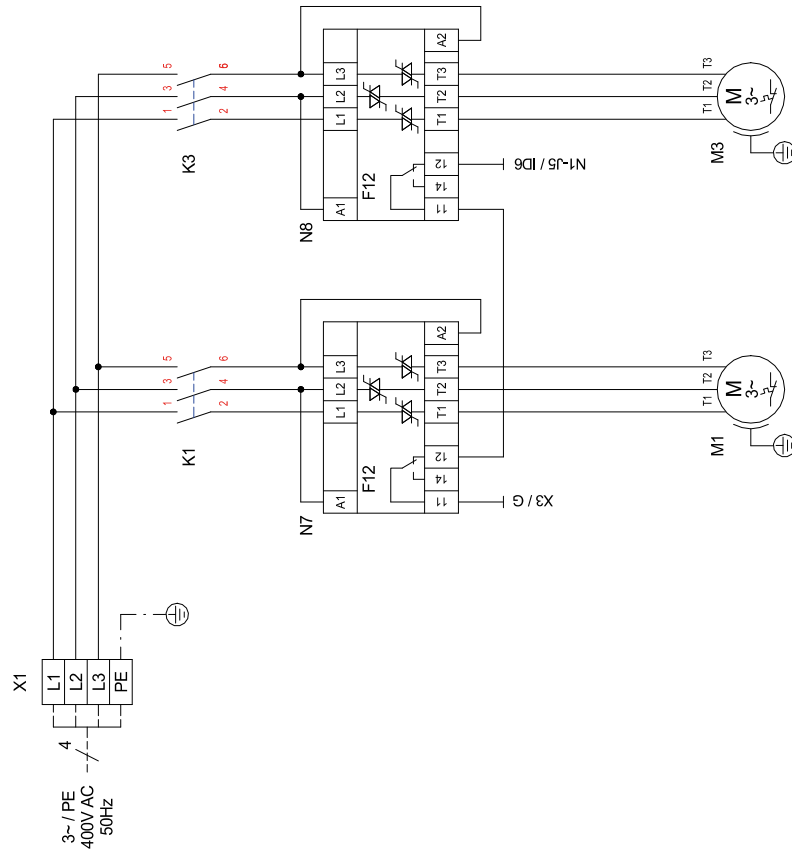

3 Circuit Diagrams

3.10 Connection Plan WWP S 35 ID

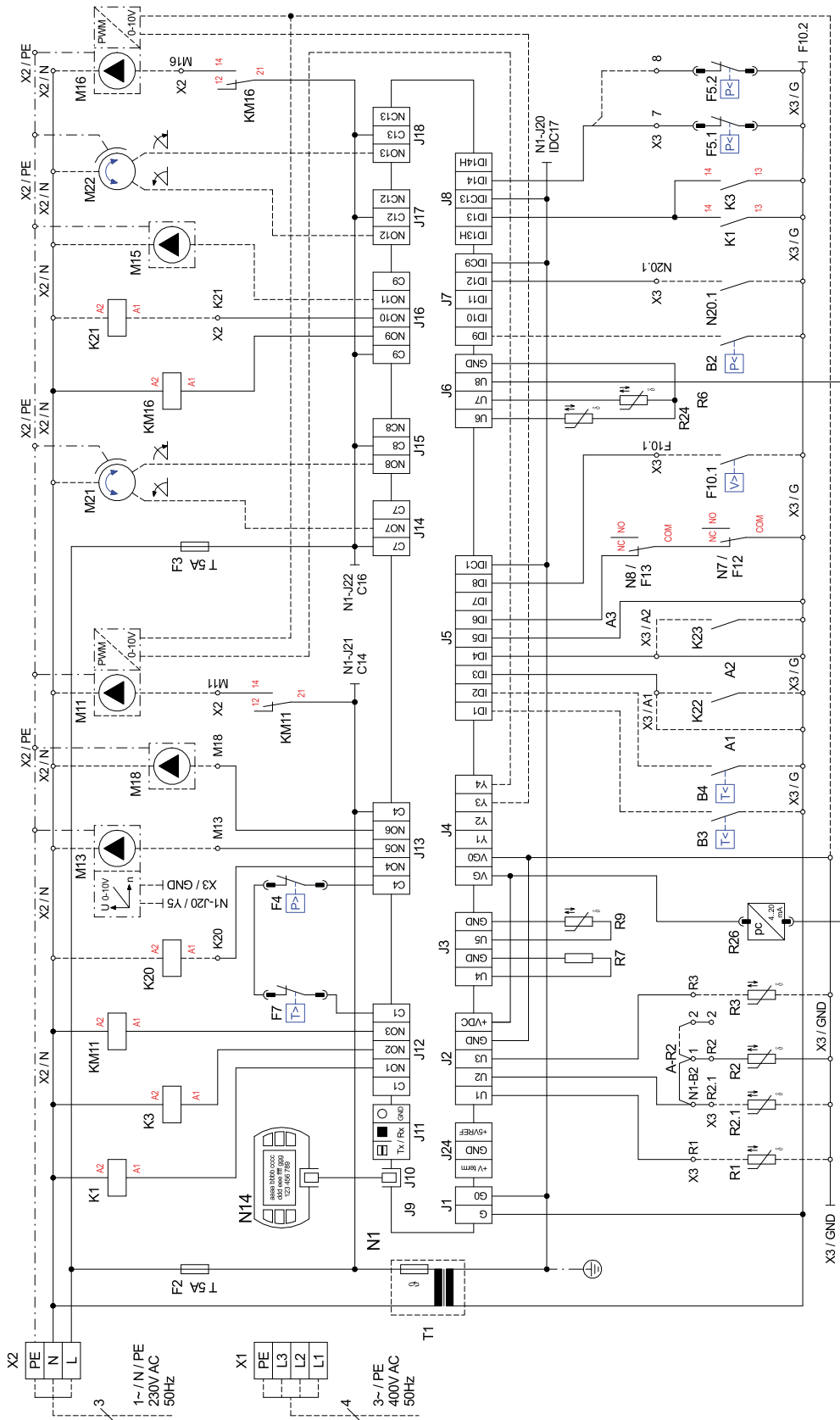

3.11 Connection Plan WWP S 35 ID

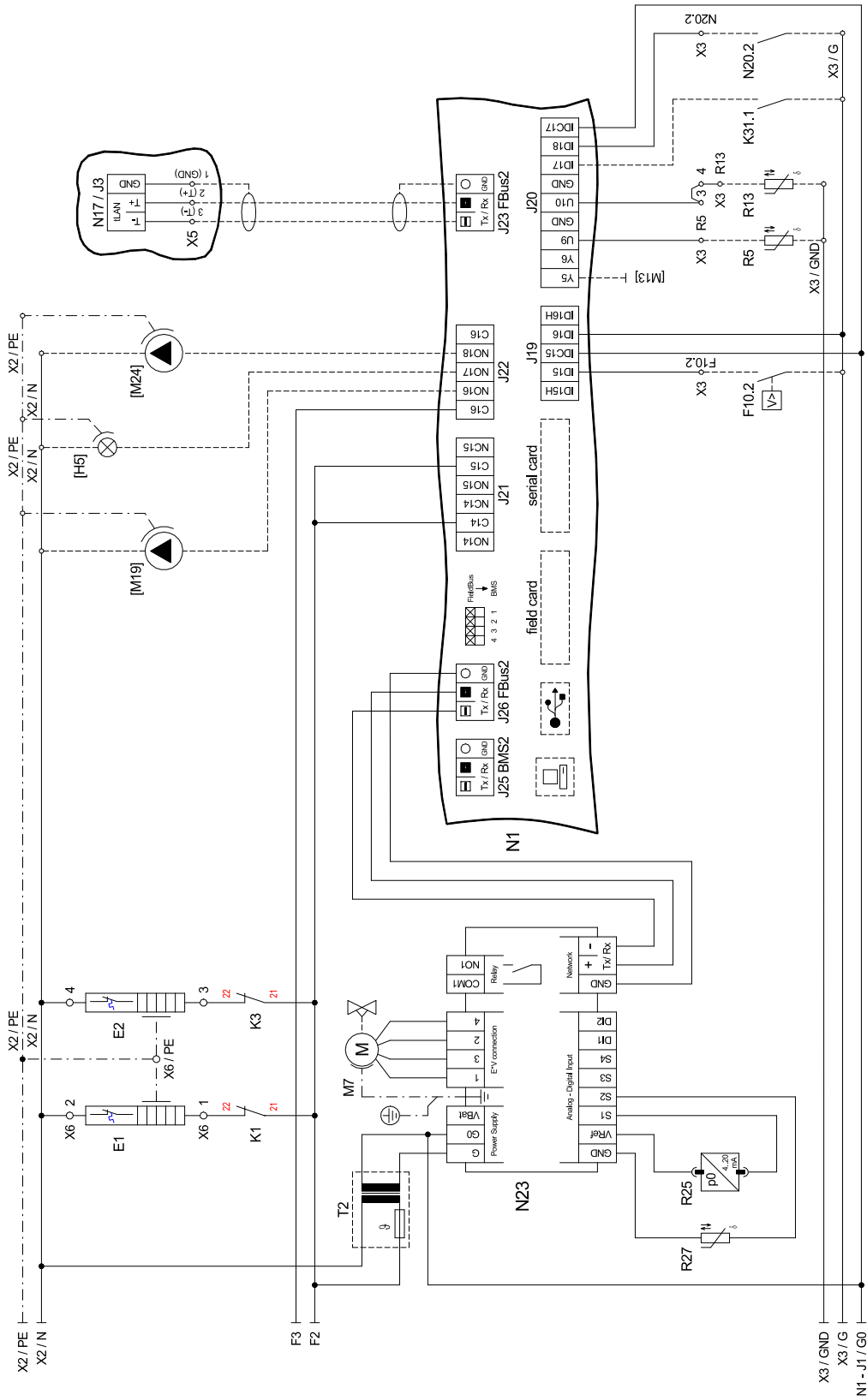



3 Circuit Diagrams

3.12 Legend WWP S 35 ID

A1	Brücke EVU-Sperre, muss eingelegt werden, wenn kein EVU-Sperrschütz vorhanden ist (Kontakt offen = EVU-Sperre)	Utility block (EVU) bridge must be inserted if no utility blocking contactor is present (contact open = utility block).	Pont de blocage de la société d'électricité, à insérer en absence de contacteur de blocage de la société d'électricité (contact ouvert = blocage de la société d'électricité)
A2	Brücke Sperre: muss entfernt werden, wenn der Eingang genutzt wird (Eingang offen = WP gesperrt)	Block bridge: Must be removed when the input is being used (input open = HP blocked).	Pont de blocage : à retirer si l'entrée est utilisée (entrée ouverte = pompe à chaleur bloquée)
A3	Brücke Störung M11: muß entfernt werden, wenn der Eingang genutzt wird (Eingang offen = Störung M11)	M11 link cable fault: must be removed when the input is being used (input open = M11 fault)	Pont défaut M11 : à retirer si l'entrée est utilisée (entrée ouverte = défaut M11)
A11	Brücke Solar: bei Verwendung eines Solarmoduls muss die Brücke entfernt werden und die Klemmstellen mit dem Solar-Modul verbunden werden.	Solar bridge: When a solar energy module is used, the bridge must be removed and the solar energy module connected to the terminal connections.	Pont solaire : en cas d'utilisation d'un module solaire, retirer le pont et connecter les bornes au module solaire.
A - R2	Brücke Rücklauffühler: - muss versetzt werden, wenn doppelt differenzdruckloser Verteiler und „Heizkreisumkehrventil“ verwendet wird. Neue Klemmstellen: X3 / 1 und X3 / 2	Return sensor bridge: - Must be moved when a dual differential pressureless manifold and a "heating circuit reversing valve" are used. New terminal connections: X3/1 and X3/2	Pont sonde sur circuit de retour : - à déplacer si le distributeur double sans pression différentielle et la « vanne d'inversion du circuit de chauffage » sont utilisés. Nouveaux emplacements de borne : X3 / 1 et X3 / 2
B2*	Niederdruckpressostat Primärkreis	Low-pressure switch, primary circuit	Pressostat basse pression circuit primaire
B3*	Thermostat Warmwasser	Hot water thermostat	Thermostat eau chaude
B4*	Thermostat Schwimmbadwasser	Swimming pool water thermostat	Thermostat eau de piscine
E1	Ölsumpfheizung M1	Oil sump heater M1	Chauffage à carter d'huile M1
E2	Ölsumpfheizung M2	Oil sump heater M2	Chauffage à carter d'huile M2
E9*	Tauchheizkörper (Warmwasser)	Immersion heater for hot water	Résistance immergée eau chaude sanitaire
E10*	2. Wärmeerzeuger	2nd heat generator	2ème générateur de chaleur
F2	Sicherung für Steckklemmen J12; J13 und J21 5x20 / 5,0AT	Fuse for plug-in terminals J12; J13 and J21 5x20 / 5.0AT	Fusible pour bornes enfichables J12 ; J13 et J21 5x20 / 5,0AT
F3	Sicherung für Steckklemmen J14 bis J18 und J22 5x20 / 5,0AT	Fuse for plug-in terminals J14 to J18 and J22 5x20 / 5.0AT	Fusible pour bornes enfichables J14 à J18 et J22 5x20 / 5,0AT
F4	Hochdruckpressostat	High-pressure switch	Pressostat haute pression
F5.1	Niederdruckpressostat Sole/Wasser-Wärmepumpe	Low-pressure switch brin-to water heat pump	Pressostat basse pression pompe à chaleur eau glycolée/eau
F5.2	Niederdruckpressostat Wasser/Wasser-Wärmepumpe	Low-pressure switch water-to water heat pump	Pressostat basse pression pompe à chaleur eau/eau
F7	Heißgasthermostat	Hot gas thermostat	Thermostat gaz chaud
F10.1*	Durchflussschalter Primärkreis	Flow rate switch for primary circuit	Commutateur de débit circuit primaire
F10.2*	Durchflussschalter Sekundärkreis	Flow rate switch for secondary circuit	Commutateur de débit circuit secondaire
F12	Störmeledekontakt N7	Fault signaling contact N7	Contact de signalisation de défauts N7
F13	Störmeledekontakt N8	Fault signaling contact N8	Contact de signalisation de défauts N8
[H5]*	Leuchte Störferrnanzeige	Remote fault indicator lamp	Témoin de télédétection de pannes
J1	Spannungsversorgung	Voltage supply	Alimentation en tension
J2-3	Analogeingänge	Analogue inputs	Entrées analogiques
J4	Analogausgänge	Analogue outputs	Sorties analogiques
J5	Digitaleingänge	Digital inputs	Entrées numériques
J6	Analogausgänge	Analogue outputs	Sorties analogiques
J7-8	Digitaleingänge	Digital inputs	Entrées numériques
J9	frei	free	libre
J10	Bedienteil	Control panel	Unité de commande
J11	frei	free	libre
J12-J18	230 V AC - Ausgänge	230 V AC outputs	Sorties 230 V AC
J19	Digitaleingänge	Digital inputs	Entrées numériques
J20	Analogausgänge; Analogeingänge, Digitaleingänge	Analogue outputs; Analogue inputs, Digital inputs	Sorties analogiques, entrées analogiques, entrées numériques
J21-22	Digitalausgänge	Digital outputs	Sorties numériques
J23	Bus-Verbindung extern	Bus connection external	Raccordement externe au bus
J24	Spannungsversorgung für Komponenten	Power supply for components	Alimentation en tension des composants
J25	Schnittstelle	Interface	Interface
J26	Bus-Verbindung intern	Bus connection internal	Raccordement interne au bus
K1	Schütz M1	Contactor M1	Contacteur M1
K3	Schütz M3	Contactor M3	Contacteur M3
K20*	Schütz E10	Contactor E10	Contacteur E10
K21*	Schütz E9	Contactor E9	Contacteur E9
K22*	EVU-Sperrschütz	Utility blocking contactor	Contacteur de coupure du fournisseur d'énergie
K23*	Hilfsrelais für Sperrereingang	Auxiliary relay for disable contactor	Relais auxiliaire pour entrée du contacteur de blocage
K31.1*	Anforderung Zirkulation Warmwasser	Domestic hot water circulation request	Demande circulation ECS
KM11	Hilfsrelais M11	Auxiliary relay M11	Relais auxiliaire M11
KM16	Hilfsrelais M16	Auxiliary relay M16	Relais auxiliaire M16
M1	Verdichter 1	Compressor 1	Compresseur 1
M3	Verdichter 2	Compressor 2	Compresseur 2
M7	Stellmotor für Expansionsventil	Actuator for expansion valve	Servomoteur pour détendeur
M11*	Primärkreispumpe	Primary circuit pump	Pompe circuit primaire
M13*	Heizungsumwälzpumpe	Heat circulating pump	Circulateur de chauffage
M15*	Heizungsumwälzpumpe 2. Heizkreis	Heat circulating pump for heating circuit 2	Circulateur de chauffage pour le 2e circuit de chauffage
M16*	Zusatzumwälzpumpe	Auxiliary circulating pump	Circulateur supplémentaire
M18*	Warmwasserladepumpe	Hot water loading pump	Pompe de charge eau chaude sanitaire

3 Circuit Diagrams

[M19]*	Schwimmbadwasserumwälzpumpe	Swimming pool circulating pump	Circulateur de la piscine
M21*	Mischer Hauptkreis oder 3. Heizkreis	Mixer for main circuit or heating circuit 3	Mélangeur circuit principal ou 3ème circuit de chauffage
M22*	Mischer 2. Heizkreis	Mixer for heating circuit 2	Mélangeur 2e circuit de chauffage
[M24]*	Zirkulationspumpe Warmwasser	Domestic hot water circulating pump	Pompe de circulation eau chaude sanitaire
N1	Regelinheit	Control unit	Unité de régulation
N7	Sanftanlaufsteuerung M1	Soft start control M1	Commande de démarrage progressif M1
N8	Sanftanlaufsteuerung M3	Soft start control M3	Commande de démarrage progressif M3
N14	Bedienteil	Control panel	Unité de commande
N17*	pCOe-Modul	pCOe module	Module pCOe
N20*	Wärmemengenzähler	Thermal energy meter	Compteur de chaleur
N23	Ansteuerung elektronisches Expansionsventil E*V connection (1 = grün; 2 = gelb; 3 = braun; 4 = weiß)	Control for electronic expansion valve E*V connection (1=green; 2=yellow; 3=brown; 4=white)	Commande détendeur électronique connexion E*V (1=vert ; 2=jaune ; 3=marron ; 4=blanc)
R1*	Außenfühler	External sensor	Sonde extérieure
R2	Rücklauffühler Heizkreis	Return sensor for heating circuit	Sonde de retour circuit de chauffage
R2.1*	Rücklauffühler Heizkreis im doppelt differenzdrucklosen-Verteiler	Return sensor for heating circuit in dual differential pressureless manifold	Sonde de retour circuit de chauffage dans le distributeur double sans pression différentielle
R3*	Warmwasserfühler	Hot water sensor	Sonde d'eau chaude
R5*	Fühler 2. Heizkreis	Sensor heating circuit 2	Sonde pour 2e circuit de chauffage
R6	Vorlauffühler Primärkreis	Flow sensor for primary circuit	Sonde aller circuit primaire
R7	Codierwiderstand	Coding resistor	Résistance de codage
R9	Vorlauffühler Heizkreis	Flow sensor for heating circuit	Sonde aller circuit de chauffage
R13*	Fühler regenerativ, Raumfühler, Fühler 3. Heizkreis	Renewable sensor, room sensor, sensor for heating circuit 3	Sonde mode régénératif, sonde d'ambiance, sonde 3ème circuit de chauffage
R20*	Schwimmbadfühler	Swimming pool sensor	Sonde de piscine
R24	Rücklauffühler Primärkreis	Return sensor, primary circuit	Sonde retour circuit primaire
R25	Drucksensor Kältekreis - Niederdruck pO	Pressure sensor for refrigerating circuit - low pressure pO	Capteur de pression circuit réfrigérant - basse pression pO
R26	Drucksensor Kältekreis - Hochdruck pc	Pressure sensor for refrigerating circuit - high pressure pc	Capteur de pression circuit réfrigérant - haute pression pc
R27	Sauggasfühler	Suction gas sensor	Sonde de gaz d'aspiration
T1	Sicherheitstransformator 230 / 24 V AC	Safety transformer 230 / 24 V AC	Transformateur de sécurité 230 / 24 V AC
T2	Sicherheitstransformator 230 / 24 V AC	Safety transformer 230 / 24 V AC	Transformateur de sécurité 230 / 24 V AC
X1	Klemmleiste Einspeisung	Terminal strip, infeed	Alimentation bornier
X2	Klemmleiste Spannung = 230 V AC	Terminal strip voltage = 230 V AC	Tension bornier = 230 V AC
X3	Klemmleiste Kleinspannung < 25 V AC	Terminal strip, extra-low voltage < 25 V AC	Faible tension bornier < 25 V AC
X6	Klemmleiste Ölsumpfheizung	Oil sump heater terminal strip	Bornier chauffage à carter d'huile
XF5	Klemmleiste F5.x	Terminal strip F5.x	Bornier F5.x
*	Bauteile sind bauseits anzuschließen / beizustellen	Components must be connected / supplied by the customer	Les pièces sont à raccorder / à fournir par le client
[]	Flexible Beschaltung - siehe Vorkonfiguration (Änderung nur durch Kundendienst!)	Flexible switching - see pre-configuration (changes by after-sales service only!)	Commande flexible - voir pré-configuration (modification uniquement par le SAV !)
-----	werkseitig verdrahtet	Wired ready for use	câblé en usine
-----	bauseits bei Bedarf anzuschließen	To be connected by the customer as required	À raccorder par le client au besoin
	ACHTUNG		ATTENTION !
	An den Steckklemmen N1-J1 bis J11, J19, J20; J23 bis J26 und der Klemmleisten X3, liegt Kleinspannung an. Auf keinen Fall darf hier eine höhere Spannung angelegt werden.		Une faible tension est appliquée aux bornes enfichables N1-J1 à J11, J19, J20, J23 à J26 et au bornier X3. Ne jamais appliquer une tension plus élevée.

4 Hydraulic integration diagram

4 Hydraulic integration diagram

4.1 Sample system diagram

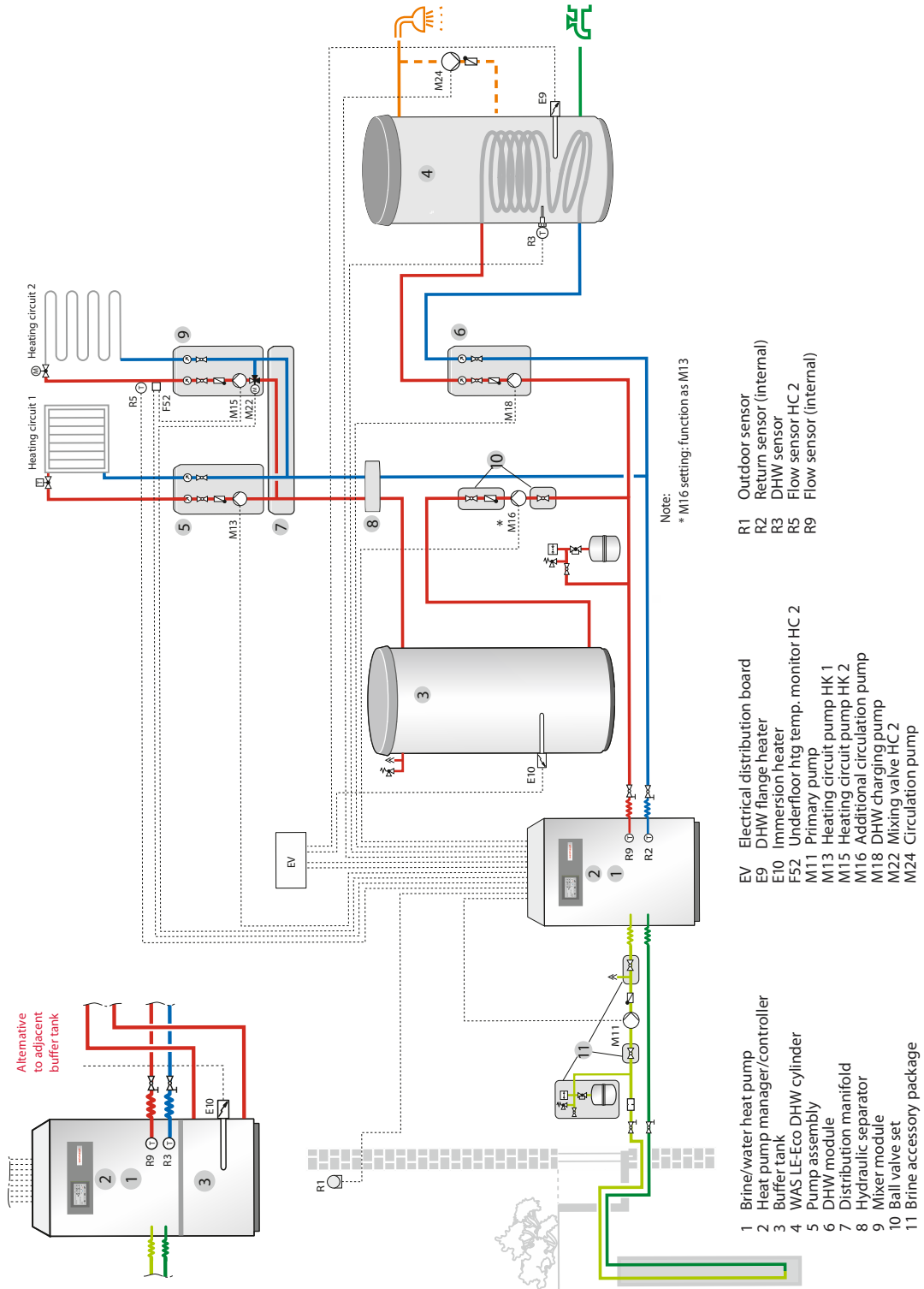

The system example is a non-binding draft design with no claims of completeness. Final system design must be carried out in consultation with an expert planner.

Das ist Zuverlässigkeit. C'est la fiabilité. That's reliability. Questa è affidabilità. 信頼性とは、ころいろものです。Това е надеждност. Ez a megbízhatóság. Đó là sự đáng tin cậy. اردن رقابارت المؤمنان است To je zanesljivost. Güvence budur. Αυτό σημαίνει αξιοπιστία. 그것은 바로 신뢰성입니다. To je spoľahlivosť. Dat is betrouwbaarheid. Täämä on luotettavuutta. هذه هي الوثوقية See on usaldusväärsus. Pouzdana tvrtka. To jest niezawodność. นั่นคือความเชื่อถือได้ Це надійність. Isto é fiabilidade. To je spolehlivost. यही विश्वसनीयता है. Det är pålitlighet. זאת אמינות. Esto es fiabilidad. Это надёжность. Itulah kepercayaan. 值得信赖。Is é sin iontaofacht. Iyan ang maaasahan. Aceasta este fiabilitatea. انتى ن س و شو سه مو Tai - patikimumas. Det er pålitelighet. Tā ir uzticamība. Sa se fyab. To je pouzdanost. La fiabilité avant tout. Det er pålidelighed.